

KLE SOCIETY'S  
**P. C. JABIN SCIENCE COLLEGE,**  
AUTONOMOUS, CPE PHASE -III  
AFFILIATED TO KARNATAK UNIVERSITY DHARWAD  
APPROVED BY UNIVERSITY GRANTS COMMISSION, NEW DELHI AND  
GOVERNMENT OF KARNATAKA  
Accredited at 'A' Grade by NAAC  
VIDYANAGAR, HUBBALLI-580031

---

**DEPARTMENT OF PHYSICS**  
**B.Sc – I semester question Bank**

**UNIT I: Frames of Reference and Linear momentum**

**Two Marks Questions**

1. What is an inertial frame of reference? Give one example.
2. Write the Galilean transformation equations.
3. What are limitations of Newton's laws of motion?
4. State hypothesis of Galilean invariance.
5. What are pseudo forces? Give an example.
6. What is Coriolis force? Give one example.
7. What are non inertial frames? Give one Example.
8. What are fictitious forces? Give one example.
9. Comment on the statement that the sun is a better frame of reference than earth for describing the motion of stars.
10. Strictly speaking earth is not an inertial frame. Explain.
11. What are elastic and inelastic collisions?
12. State principle of conservation of linear momentum?
13. What are the factors affecting velocity of the rocket?
14. Velocity of exhaust gas of the rocket is optimized at the starting. Justify?
15. What is double stage rocket?
16. Where does centre of mass of triangular plate and a thin uniform rod lie?
17. Where does centre of mass of semicircular lamina lie?
18. What is center of mass?
19. What do you mean by collision precisely?

20. Name the liquid fuels and oxidation used in liquid type rocket.

### **Five Marks Questions**

1. Derive Galilean transformation equations
2. Find the transformation equations connecting two frames  $S$  and  $S^1$  that their origins and Z-axis are coincident and the frames  $S^1$  rotates about the common Z-axis with uniform angular velocity
3. Obtain the Galilean transformations equations, when two frames  $S$  and  $S'$  are moving with uniform relative velocity.
4. Show that Newton's laws of motion are invariant under Galilean transformation.
5. State and explain hypothesis of Galilean invariance.
6. Explain Galilean principle of invariance of space and time.
7. Describe the Foucault's pendulum.
8. Show that linear momentum is conserved under Galilean transformations.
9. Show that energy is conserved under Galilean transformations.
10. Show that velocity is not invariant under Galilean transformations.
11. Distinguish between inertial and non-inertial frames of reference.
12. State and explain the law of conservation of linear momentum for a system of particles.
13. What is the centre of mass? Show that in the absence of external forces, the velocity of the centre of mass remains constant.
14. Discuss the inelastic collision between two particles in laboratory. Show that K.E. after collision is less than before collision.
15. What is double stage rocket? What are its advantages over single stage rocket?
16. The total electrical energy generated in a country in a particular year was  $7.5 \times 10^{11}$  kWh. How much mass was converted in to energy?
17. If 4 kg of a substance is fully converted into energy, how much energy is produced?

18. A particle of mass  $10^{-24}$  kg is moving with a speed of  $1.8 \times 10^8$   $\text{ms}^{-1}$ . Calculate its mass when it is in motion.

### Ten Marks Questions

1. Derive Galilean transformation equations. Prove that length is invariant in Galilean transformation.
2. State and explain hypothesis of Galilean invariance. Show that Newton's laws of motion are invariant under Galilean transformation.
3. Obtain the Galilean transformations equations, when two frames S and S' are moving with uniform angular velocity.
4. Explain the concept of center of mass. Find out the expression for Poisson vector and velocity of center of mass.
5. Discuss the inelastic collision between two particles in laboratory and in centre of mass frames of reference.
6. Discuss the elastic collision between two particles in laboratory and in centre of mass frame of reference.
7. What is multi stage rocket? What are its advantages over single stage rocket? Derive the expression for velocity of single stage rocket at any instant of time by considering the weight of the rocket.

### **UNIT II: Rigid body dynamics (Moment of Inertia & angular momentum)**

#### Two Marks Questions

1. Define moment of inertia. Mention its SI unit.
2. On what factors M.I. of body depends
3. What happens to the moment inertia when a gymnast sitting on a rotation stool with his arms stretched suddenly lowers his arms.
4. Define radius of gyration. Mention its SI unit.

5. Write the expression for MI of a hollow cylinder about an axis passing through its center.
6. State the theorem of parallel axes.
7. State the theorem of perpendicular axes.
8. What is gyroscope?
9. Without weighing how will you distinguish between the two identical balls of the material, one being solid and the other being hollow?
10. What is the K.E. of a rotating body of moment of inertia  $I$  and angular velocity  $\omega$  ?
11. On what factors the M.I. of a body does not depend upon?
12. Write the expression for M.I. of a rectangle lamina of mass  $M$ , length  $L$  and breadth  $B$  about an axis through its center of gravity and perpendicular to its length?
13. What is bifilar suspension?
14. State the law of conservation of angular momentum.
15. What is the expression of time period of Bifilar suspension for parallel threads
16. Mention the expression for time period of compound pendulum.
17. What is escape velocity?
18. What is stationary satellite?
19. Define Spin and orbital angular momentum.

### **Five Marks Questions**

1. Derive expression of M.I. of solid cylinder about its own axis.
2. State and prove the theorem of perpendicular for M.I.
3. State and prove the theorem of parallel axes for M.I.
4. Obtain an expression for M.I. of a rectangle lamina about an axis passing through its center and perpendicular to the plane of the lamina.

5. Derive an expression for K.E. of a rotating body.
6. Write a note on gyroscope and its applications.
7. Obtain the expression for 'g' in the case of bifilar suspension with parallel threads.
8. Derive an expression for period of a compound Pendulum.
9. State and explain the Kepler's second law.
10. Obtain an expression for the escape velocity of a satellite.
11. State the law of conservation of angular momentum with illustrations.
12. Obtain the expression for time period of bifilar suspension with parallel threads.
13. State the law of conservation of angular momentum. show that the sum of all internal torques is zero.
14. A solid sphere of mass 1 kg and radius 0.25 m rolls without slipping with a uniform velocity of  $0.1 \text{ ms}^{-1}$  along a straight line on a horizontal table. Calculate its kinetic energy.
15. A thin hollow cylinder open at both ends and weighing 10 kg (a) slides with a speed of  $10 \text{ ms}^{-1}$  without rotating (b) rolls with a speed of  $10 \text{ ms}^{-1}$  without slipping. Calculate the kinetic energy of the cylinder in each case.
16. A thin uniform bar of 1.2m is made to oscillate about an axis through its end. Find the period of oscillation and other points about which it can oscillate with the same period.
17. A thin uniform bar of length 1.2m is made to oscillate about an axis through its end. Find the period of oscillation and length of equivalent simple pendulum.
18. Calculate the distance between center of suspension and center of oscillation of a thin uniform cylindrical bar used as second's pendulum ( $T=2\text{sec}$ )
19. A uniform rod 1 m in length oscillates about horizontal axis perpendicular to its length. Find the position of points about which the time period is minimum. If  $g = 9.8 \text{ ms}^{-2}$ . Find the minimum period of oscillations.

20. A straight uniform stick is oscillating about an axis perpendicular to its length and passing through one of its ends. If its time period is 2.168 sec. Calculate its length assuming the value of  $g$  to be  $9.8 \text{ ms}^{-2}$
21. A thin meter stick is used as compound pendulum with one of its ends as center of suspension. Find its time period.
22. A uniform bar of 2 meter oscillates about a knife edge 0.5m from one end. Calculate the period of oscillation.
23. A body of mass 0.2 kg oscillates about an axis at a distance of 0.2 m from its center of gravity. If the length of equivalent simple pendulum be 0.35 m. Find its moment of inertia about the axis of suspension.

### **Ten Marks Questions**

1. Derive an expression of M.I. of a uniform circular disc about its axis.
2. Explain M.I. and radius of gyration. State and prove theorem on perpendicular axis.
3. Derive expression for M.I. of a solid cylinder about a standard axis.
4. Obtain an expression for M.I. of a rectangle lamina about an axis passing through its center and parallel to one of its sides.
5. State and prove the theorems of moment inertia.
6. Derive an expression for the M.I. of a solid cylinder about its own axis. Obtain an expression for Period in the case of bifilar suspension with parallel threads.
7. (a) What is bifilar suspension?  
(b) Derive the expression for time period of bifilar suspension for parallel threads.

### **UNIT III: Gravitation**

#### **Two marks questions**

1. Define gravitational field.
2. Define gravitational potential field.

3. What is the intensity of the gravitational field.
4. Write the expression for the gravitational potential at a point outside the spherical shell.
5. Write the expression for the gravitational attraction at a point on the spherical shell.
6. Mention the expression for the gravitational field at a point inside the solid sphere.
7. Define gravitational self energy.
8. Mention the expression for the gravitational self energy of a uniform solid sphere and explain the terms.

#### **Five marks questions**

1. Derive the expression for the gravitational potential at a point outside the spherical shell.
2. Derive the expression for the gravitational attraction due to a spherical shell at a point inside the shell.
3. Explain the Boy's method to determine the gravitational constant.
4. Define gravitational self energy and derive the expression for it for uniform solid sphere.
5. Calculate the gravitational self energy of earth. How many calories of heat must be produced during the gravitational condensation of earth from dust particle?
6. The system consists of three particles of masses 2 kg, 4 kg, and 6 kg are placed at the vertices of an equilateral triangle of sides 1m. Find the gravitational self energy of this system (Given:  $G = 6.67 \times 10^{-11}$  SI units).
7. What is the self energy of mass 2 kg on the surface of the earth and at a distance of  $10^5$  km from the centre, referred to zero potential energy at infinite distance. (Given:  $G = 6.67 \times 10^{-11} \text{ Nm}^2\text{kg}^{-2}$ , mass of the earth =  $6 \times 10^{24}$  kg and the radius of earth  $R = 6.4 \times 10^6$  m).

8. Calculate the mass of the Sun, given that the distance between the Sun and the earth is  $1.5 \times 10^{11}$  m and  $G = 6.67 \times 10^{-11} \text{ Nm}^2\text{kg}^{-2}$ .

**Ten marks questions**

1. Derive Newton's law of gravitation from Kepler's laws of motion.
2. Derive the expressions for gravitational potential for spherical shell at a point  
Outside  
On the surface  
Inside
3. Derive the expression for the gravitational potential for spherical shell at a point  
(a) Outside (external)  
(b) On the surface  
(c) Internal
4. Define the gravitational constant and explain the Cavendish's method to determine the gravitational constant with theory.

**UNIT IV: Properties of matter (Elasticity, Surface Tension and Viscosity)**

**Two Mark Questions**

1. State Hooke's law. What is elastic limit?
2. What are the dimensions of modulus of elasticity?
3. Define Poisson's ratio. What are its limiting values?
4. Define Young's modulus and modulus of rigidity.
5. Write the relation between Young's modulus, bulk modulus and modulus of rigidity
6. What is cantilever?
7. Define the terms, plane of bending and neutral axis.
8. State any two assumptions made in obtaining the expression for depression of cantilever.



9. What are the limits of Poisson's ratio?
10. Define rigidity modulus and Poisson's ratio.
11. Write the relation between young's modulus, rigidity and bulk modulus.
12. What is Double cantilever?
13. Define bending moment
14. What is Maxwell's needle?
15. What is the value of the Poisson's ratio for a body which is easily compressible.
16. What type of modulus is involved when a body is under torsion?
17. What is the unit of Poisson's ratio?
18. What is the period of a torsional pendulum?
19. Define surface tension and angle of contact.
20. Explain the terms "Molecular range" and "sphere of influence".
21. On what factors "angle of contact" depends.
22. If  $T$  is the surface tension and ' $R$ ' is the radius, what is the excess pressure inside an air bubble in a liquid.
23. Explain "Surface tension" and " Surface energy"
24. What is the angle of contact of pure water with glass?
25. What The angle of contact of mercury with glass?
26. Calculate the excess pressure in a soap bubble of radius 10mm, if the surface tension of soap solution is  $3.2 \times 10^{-2}$  N/m.
27. Find the excess pressure inside the spherical drop of water of diameter 4mm. Given that surface tension of water is  $73 \times 10^{-3}$  N/m.
28. Explain movement of Camphor particle on surface of water.
29. Find the excess of pressure inside a spherical drop water of diameter 4 mm, given that surface tension of water is  $73 \times 10^{-3}$  N/m.
30. Why Small drops of mercury are practically spherical?
31. Calculate the pressure difference between inside and outside of a soap bubble of

radius 0.01m given that S.T. of soap solution = 0.032 N/m.

32. Write the Dimensional formula of co-efficient of viscosity.

On which factors the viscosity of liquid drop depends.

33. What is terminal velocity?

34. State the Newton's law of Viscous flow in stream line motion

35. Mention any two assumptions made in the derivation of the expression for flow rate.

36. Explain the terms "Streamline flow" and "Turbulent flow".

37. Define coefficient of viscosity and mention the SI unit of it.

### **Five Mark Questions**

1. Write a note on behavior of a wire under gradually increasing load.

2. Write the expressions for Young's modulus, bulk modulus & modulus of rigidity.

3. Mention different types of elastic moduli and explain them.

4. Obtain an expression for the twisting couple on a cylinder fixed at one end and twisted at the free end.

5. Using a torsion pendulum how the modulus of rigidity of the material of a wire can be determined?

6. Explain Maxwell's needle method to determine the modulus of rigidity ' $\eta$ '

7. A wire of length 2m is fixed at one end and a force of 10N is applied at the other end the area of cross-section of the wire is  $2 \times 10^{-6} \text{m}^2$  and the young's modulus of elasticity of its material is  $2 \times 10^{10} \text{ N/m}^2$ . Calculate the stress and strain.

8. A steel wire of 0.5 mm radius is bent to form a circle of 0.1m radius. What is the bending moment and the maximum stress if  $Y = 2 \times 10^{10} \text{ Newton's/m}^2$

9. Calculate the young's modulus for a material for which  $K = 14 \times 10^{10} \text{ N/m}^2$  and  $\eta = 4.2 \times 10^{10} \text{ N/m}^2$

10. A wire 4m long 0.3 mm in diameter is stretched by a force of 0.8 kg-wt. If the extension

amount to 1.5 mm, calculate the energy stored in the wire.

11. A wire of length 1 meter and diameter 1mm is fixed at one end and couple is applied at the other end so that the wire is twisted by  $\pi/2$  radian. Calculate the moment of the couple required if the rigidity of the modulus is  $2.8 \times 10^{10} \text{ N/m}^2$
12. Calculate the value of Poisson's ratio if Young's modulus and rigidity modulus are  $12.25 \times 10^{10} \text{ Nm}^{-2}$  and  $4.5 \times 10^{10} \text{ Nm}^{-2}$  respectively.
13. Calculate the work done in twisting a steel wire of radius 1mm and length 0.25m through an angle of  $45^\circ$ . Its modulus of rigidity is  $8 \times 10^{10} \text{ Nm}^{-2}$ .
14. Find the work done in stretching a wire of cross section  $1 \text{ sq. mm}$  and length 2m through  $0.1 \text{ mm}$ . Given  $Y = 2 \times 10^{11} \text{ Nm}^{-2}$
15. Obtain the expression for excess pressure inside a liquid drop.
16. Describe an experiment to determine surface tension of water by capillary-rise method.
17. Calculate the height to which water will rise in a capillary tube of 1mm diameter. The angle of contact for water is zero and surface tension of water is  $0.072 \text{ Nm}^{-1}$ . The density of water is  $103 \text{ Kgm}^{-3}$ .
18. Find the pressure inside a small air bubble of diameter 0.2mm situated just below the surface of water. Surface tension of water is  $70 \times 10^{-3} \text{ N/m}$ . Atmospheric pressure is  $1.013 \times 10^5 \text{ Nm}^{-2}$ .
19. In a capillary tube water rises to a height of 0.1m. In the same capillary tube mercury is depressed by  $3.42 \times 10^{-2} \text{ m}$ . Angle of contact for water  $= 0^\circ$ . Angle of contact for mercury  $= 135^\circ$ . Calculate the S.T of mercury, given that S.T of water as  $72 \times 10^{-3} \text{ N/m}$ . Density of mercury  $= 13.6 \times 10^3 \text{ kg/m}^3$
20. Calculate the, S.T of paraffin liquid if it rises to a height of  $0.75 \times 10^{-2} \text{ m}$  in a capillary tube of radius 0.75 mm. Density of paraffin  $\rho = 800 \text{ kg/m}^3$  and angle of contact is  $28^\circ$ .
21. What would be the pressure inside a small air bubble of 0.1 mm radius, situated just below the surface of water? Surface tension of water  $= 72 \times 10^{-3} \text{ N/m}$  and atmospheric pressure  $= 1.013 \times 10^5 \text{ Nm}^{-2}$ .

22. In Jaeger's experiment, a capillary tube of internal diameter  $5 \times 10^{-4}$  m dips  $3 \times 10^{-2}$  m inside the water contained in a breaker. The difference in level of a water manometer when the bubble is released is 0.09 m. Calculate the S.T. of water.
23. Derive an expression for the excess of pressure on a curved surface of a membrane.
24. Explain Stoke's method of determining the viscosity of a liquid.
25. Obtain an expression for the volume of the liquid flowing per second through a uniform tube.
26. An air bubble of radius 0.01 m is allowed to rise through a long cylindrical column of viscous liquid and travels at steady rate of  $0.021 \text{ms}^{-1}$  of the density of the liquid is  $1470 \text{kg m}^{-3}$ . Find its viscosity,  $g=9.8 \text{ms}^{-2}$  neglecting the density of air.
27. A spherical ball of radius 2mm and mass  $1.4 \times 10^{-4}$  kg takes 6.4 second to fall steady through a height of 0.32m.inside a large volume of oil of density  $900 \text{kg m}^{-3}$ . Calculate the co-efficient of viscosity of the oil ( $g=9.8 \text{ms}^{-2}$ ).

### Ten Mark Questions

1. Derive the relation connecting Young's modulus, bulk modulus and modulus of rigidity
2. Derive an expression for torsional rigidity of a wire.
3. Obtain an expression for the depression at the loaded end of the cantilever, when the other end is fixed (Neglect the weight of the cantilever)
4. Explain with theory Maxwell's needle method to determine the modulus of rigidity.
5. Define young's modulus and Rigidity modulus. Derive an expression for the depression at the end of loaded single cantilever.
6. Explains with theory torsional pendulum to determine modulus of rigidity.
7. Obtain an expression for depression at the midpoint of cantilever.
8. With necessary theory, describe an experiment to determine the surface

tension of a liquid by Jaeger's method.

9. Describe with relevant theory, Quincke's method of determining the surface tension of mercury.
10. Describe Quincke's method of measuring the surface tension and the angle of contact for mercury in the form of a large flat drop.

## **UNIT V: Waves and Sound**

### **Two Marks Questions**

1. Define S.H.M
2. What is the velocity of a particle executing SHM and mention when it is maximum and minimum?
3. Give the graphical representation between displacement and time of a particle starting with mean position performing SHM.
4. Give the graphical representation between displacement and time of a particle that starts from mean position performing SHM.
5. Define reverberation time.
6. State Fourier theorem.
7. Write Sabine's formula and explain the usual terms?
8. Define the terms phase and phase difference in connection with a particle performing SHM.
9. Draw the nature of P.E. and K.E. curves w.r.t. displacement.
10. What are Lissajous figures ?
11. Write the expression for average K.E. and P.E. of a particle performing SHM.
12. Write the expression for total energy of a particle performing SHM.

### Five Marks Questions

1. What is SHM? Obtain expression for velocity and a acceleration of particle performing SHM.
2. Define displacement, amplitude, acceleration, phase and period of a particle performing SHM.
3. Explain Fourier theorem.
4. Give the theory of forced vibrations.
5. Give the theory of Helmholtz resonator.
6. Give the theory of undamped free vibrations.
7. Explain the Fourier theorem for square wave.
8. Explain the Fourier theorem for saw tooth wave.
9. Explain Sabine's formula?
10. Explain Lissajous figures with five special cases.
11. Obtain an expression for average K.E. of a particle performing SHM.
12. Obtain an expression for average P.E. of a particle performing SHM.
13. A body executes SHM such that its velocity at the mean position is 1 m/s and the acceleration at one of the extremities is  $1.57 \text{ m/s}^2$  Calculate the period.
14. A particle executes SHM of period 20 s and amplitude 0.02 m. Find the distance that it travels in 5s starting from zero displacement.
15. A body in SHM executes 100 vib/min and its speed at its mean position is 15 cms/s. What is the length of its path? What is its velocity when it is half way between its mean position and an extremity of its path?
16. A particle executes SHM of period 16 s. Two seconds after it passes the center of oscillation its velocity is found to be 4 cm/s. Find the amplitude.
17. A particle executing SHM has velocities of 0.8 m/s when displacements at 0.03 and 0.04 respectively. Calculate the amplitude of vibration and its velocity at distance 0.05 from the mean position.

18. The volume of a room is  $600 \text{ m}^3$  and its surface area is  $460 \text{ m}^2$ . If the average sound absorption co-efficient is 0.24. Calculate the time of reverberation.
19. A Helmholtz resonator has volume of  $0.001 \text{ m}^3$ . The radius of the neck is 0.01m. and the length of neck is 0.05m. Calculate the natural frequency of resonator. If the velocity of sound at room temperature is 350 m/sec.
20. A Helmholtz resonator has volume of  $0.001 \text{ m}^3$ . The radius of the neck is 0.01m. and the length of neck is 0.02m. Calculate the frequency at resonance. Velocity of sound at room temperature is 340 m/sec.
21. A Helmholtz resonator has volume of  $0.2 \text{ m}^3$ . The radius of the neck is 0.005m. and the length of neck is 0.01m. Calculate the frequency at resonance. Velocity of sound at room temperature is 340 m/sec.
22. A cinema hall has a volume of  $7500 \text{ m}^3$ . It is required to have the reverberation time of 1.5 sec. What should be the total absorption in the hall?
23. A lecture hall has a volume of  $120,000 \text{ m}^3$ . It has reverberation time of 1.5 sec. What is average absorbing power total surface area is  $25,000 \text{ m}^2$ ?
24. In an auditorium a volume of  $1.275 \text{ m}^3$  is found to have reverberation time 1.5 sec. What is the total absorbing power of all the surface in the auditorium. If the area of surface absorbing the sound is  $745 \text{ m}^2$ . Calculate the adsorption co-efficient.
25. A Helmholtz resonator has a volume of  $8 \times 10^{-4} \text{ m}^3$ . The radius of the neck is  $1 \times 10^{-2} \text{ m}$  and the length of the neck is  $3 \times 10^{-3} \text{ m}$ . Calculate the natural frequency of the resonator. Given velocity of sound at room temperature is 350 m/sec.

### Ten Marks Questions

1. Derive an expression for the total energy performing SHM.
2. Find the resultant of two mutually perpendicular SHM's having same period but different phases and amplitudes.

3. Define SHM. Derive an expression for the energy of particle executing SHM.
4. Define SHM. Show that if two SHM's are at right angles to each other the resultant motion is ellipse when the phase difference between them is  $\pi/4$ .
5. (a) Set up a differential equation for a particle executing SHM.  
(b) Obtain an expression for K.E. of a particle executing SHM.
6. Derive expression for displacement, velocity and acceleration of a particle in SHM assuming that it starts from its mean position.
7. Discuss the composition of two SHM's at right angles to each other.
8. Give the theory of Helmholtz resonator.
9. Write a note on Fourier theorem with square wave.
10. (a) What are Lissajous figure?  
(b) Explain Lissajous figure with five special cases.
11. Discuss the construction and theory of Helmholtz resonator.
12. What is reverberation? Derive Sabine's formula for period of reverberation.
13. Give the theory of damped vibrations and discuss its result.
14. Give the theory of Helmholtz resonator. Mention the applications of Helmholtz resonator.





KLE SOCIETY'S

**P. C. JABIN SCIENCE COLLEGE,**

**AUTONOMOUS, CPE PHASE -III**

AFFILIATED TO KARNATAK UNIVERSITY DHARWAD  
APPROVED BY UNIVERSITY GRANTS COMMISSION, NEW DELHI AND  
GOVERNMENT OF KARNATAKA

**Accredited at 'A' Grade by NAAC**

**VIDYANAGAR, HUBBALLI-580031**

## **DEPARTMENT OF PHYSICS**

### **UNIT - 1 : KINETIC THEORY OF GASES**

#### **2 Marks Questions**

##### **Kinetic model of a gas:**

1. At what temperature, pressure remaining constant will the R.M.S. velocity of hydrogen be double?
2. Write an expression for R.M.S. velocity of a gas and explain the terms.
3. At what temperature, pressure, remaining unchanged will the R.M.S. velocity of the gas be half its value at 0°C.

##### **Transport phenomena:**

4. What are transport phenomena in a gas?
5. Mention how coefficient of viscosity of gas varies with temperature & pressure.
6. What is the relation between viscosity ( $\eta$ ) and thermal conductivity ( $k$ )?
7. Define the term free path.  
or  
What is 'mean free path'?

##### **Brownian motion:**

8. What is Brownian motion?
9. Write expression for mean square displacement of Brownian particles from Einstein's theory.

#### **5 Marks Questions**

##### **Kinetic model of a gas:**

1. Write assumptions of Kinetic theory of gases.
2. Explain kinetic concept of temperature.
3. Write a note on kinetic model of a gas.
4. Calculate the RMS velocity of molecules of oxygen at 30°C, if  $R = 8.314 \text{ Jmole}^{-1}\text{K}^{-1}$  and molecular weight of oxygen = 32.
5. Calculate the K.E. of 10<sup>-3</sup> kg of the molecules of helium at 300K.  $R = 8.314 \text{ Jmole}^{-1}\text{K}^{-1}$ . Molecular weight of helium = 4. Given that  $R = 8.314 \text{ Jmole}^{-1}\text{K}^{-1}$  & atomic

weight of chlorine is 35.5, find the R.M.S. velocity of chlorine molecule at  $0^{\circ}\text{C}$

**Transport phenomena:**

6. Define mean free path. Derive the expression  $\lambda = 1/\pi\sigma^2n$
7. Write a note on viscosity of gas.
8. Derive the expression for coefficient of diffusion of gas.
9. Derive an expression for the coefficient of thermal conductivity of gas.
10. Derive Poisson's equation for perfect gas.
11. If the coefficient of viscosity of a gas is  $1.66 \times 10^{-5} \text{ N}\cdot\text{sec}\cdot\text{m}^{-2}$ , density =  $1.25 \text{ kgm}^{-3}$  and average velocity =  $4.5 \times 10^2 \text{ ms}^{-1}$  find **a)** mean free path **b)** collision frequency **c)** molecular diameter.
12. Calculate the mean free path for benzene, if the no. of molecules per cubic meter is  $2.79 \times 10^{25}$  and diameter of benzene molecule is  $7.2 \text{ \AA}$ .
13. Calculate the diameter of a gas molecule, if the no. of molecules per cubic meter is  $2.79 \times 10^{25}$  and the mean free path of the gas is  $2.2 \times 10^{-6} \text{ cm}$ .
14. If the coefficient of viscosity of nitrogen is  $1.66 \times 10^{-5}$  SI units and coefficient of conductivity is  $14.88 \times 10^{-3}$  SI units, find the specific heat of nitrogen at constant volume.
15. The collision frequency of a gas molecule is  $10^6$  collision/ sec. If the velocity of the molecule is  $2 \times 10^5 \text{ ms}^{-1}$ , find out the mean free path.
16. Creation gas has a density of  $1.2 \text{ kg m}^{-3}$  at a pressure  $10^5 \text{ N m}^{-2}$  and at temperature  $0^{\circ}\text{C}$  Find R.M.S. velocity.
17. If the molecular velocity of a gas at NTP is  $4.659 \times 10^2 \text{ m}^{-1}$  calculate the density of the gas.
18. Calculate the diameter of a gas molecule, if the number of molecules per  $\text{cm}^3$  is  $2.8 \times 10^{19}$  and the mean free path of the gas is  $2.2 \times 10^{-6} \text{ cm}$ .

**10 Marks Questions**

1. **Kinetic model of a gas:** Derive the expression for pressure exerted by gas molecules in an enclosed vessel.

**Transport phenomena:**

2. What is mean free path? Write the approximate expression for mean free path. Derive Clausius expression for it.
3. Obtain the expression for coefficient of viscosity from Kinetic theory of gases.
4. Obtain the expression for coefficient of thermal conductivity from Kinetic theory of gases.
5. What are transport phenomena? Derive an expression for the coefficient of thermal conductivity.
6. Derive an expression for the diffusion of gas.

**Brownian motion:**

7. Give Einstein's theory of Brownian motion.
8. Explain Brownian motion. Discuss Langevin's theory of Brownian motion.
9. Explain Brownian motion. Discuss Einstein's theory of Brownian motion.

**UNIT -2 : STATISTICAL PHYSICS**

## 2 Marks Questions

1. Define probability.
2. State postulate of equal a priori probability.
3. Define thermodynamic probability.
4. Give the additive law of probability.
5. What is joint probability rule?
6. Explain the conditional probability rule.
7. What do you mean by macrostate and microstates?
8. Define accessible and inaccessible states.
9. What do you mean by most probable distribution?
10. Mention any two limitations of Maxwell-Boltzmann method.
11. What are three kinds of particles in statistical physics?
12. What do you mean by distinguishable and indistinguishable particles?
13. What is difference between classical statistics and Quantum statistics?
14. What are Bosons? Which statistics is used to study them?
15. What are Fermions? Which statistics is used to study them?
16. A card is drawn from a well shuffled pack of 52 cards. Calculate the probability for this card to be a king.
17. We throw a dice and obtain two numbers. What is the probability that these numbers are 6 and 4 precisely in that order?

## 5 Marks Questions

1. Explain the concept of probability with examples.
2. State and explain the concept of equal a priori probability with example.
3. Define and explain the terms macrostate and microstate with the help of an example.
4. What do you mean by thermodynamic probability of macrostate? How is related to probability of occurrence of that state.
5. Define thermodynamic probability. For  $n$  distinguishable particles to be distributed in two compartments, prove that the thermodynamic probability is,  
$$W_{(n_1, n_2)} = \frac{n!}{n_1! n_2!}, \text{ where } n_1 + n_2 = n$$
6. Distinguish between probability and frequency.
7. A card is drawn from a well shuffled pack of 52 cards. Calculate the probability for this card to be either a king or a queen.
8. What is the probability of drawing two queens in succession from a pack of 52 cards?
9. If a pair of 6 faced dice with faces marked 1 to 6 are thrown. What is the probability that the sum of the numbers which shows up is 8?
10. Two six faced dice, each marked 1 to 6 are thrown. Calculate the probability that one of the dice shows 6 and the other shows 5.
11. We throw a dice and obtain three numbers. What is the probability that these numbers are 6, 5 and 4 precisely in that order?
12. Calculate the probability that in tossing a coin 8 times, we get 5 heads and 3 tails.

13. Ten distinguishable particles are distributed among three, equal size partitions. Find the probability of the macrostates (i) (4,4,2) (ii) (5,3,2)
14. Distinguish between three kinds of particles.
15. From Maxwell-Boltzmann distribution law show that
 
$$n(E)dE = 2\pi N / (nkT)^{3/2} \cdot E^{1/2} \cdot \exp(-E/kT) dE$$
13. Treating ideal gas as a system governed by classical statistics, derive the Maxwell's distribution law for molecular speeds.
14. Define root mean square speed of the gas molecules. Using Maxwell's law for distribution of molecular speeds, derive expression for root-mean square speed.
15. What is most probable speed of the gas molecules? Using Maxwell's law for distribution of speeds of molecules, derive expression for most probable speed.
16. Using Maxwell's law for distribution of speeds of molecules, derive expression for the average speed of gas molecules.

### **10 Marks Questions**

1. Find the expression for the probability of a macrostate corresponding to the distribution of n particles in k compartments of unequal sizes.
2. Treating ideal gas as a system governed by classical statistics, derive the Maxwell's distribution law for molecular speeds. Discuss special cases.
3. Using Maxwell's law for distribution of speeds of molecules in a gas, obtain expression for average speed and root-mean square speed.
4. Using Maxwell's law for distribution of speeds of molecules in a gas, obtain expression for most probable speed and average speed.
5. Using Maxwell's law for distribution of speeds of molecules in a gas, obtain expression for most probable speed and root-mean square speed.
6. Treating ideal gas as a system governed by classical statistics, derive the Maxwell's distribution law for molecular velocities. Discuss special cases.
7. Derive the Maxwell's distribution law for molecular velocities. Discuss special cases
8. Describe experimental verification of the Maxwell-Boltzmann distribution law for molecular speeds.
9. Distinguish between (or compare) Maxwell-Boltzmann statistics, Fermi-Dirac statistics and Bose-Einstein statistics.

### **UNIT -3: HEAT**

### **2 Marks Questions**

#### **Thermometry:**

1. Mention the thermometric properties of i) Magnetic thermometers ii) Gas thermometers iii) Resistance thermometers
2. What is Seebeck effect?
3. Give the principle of platinum resistance thermometer
4. Give the principle of thermoelectric thermometer.
5. Define the neutral temperature of thermocouple.
6. Define the terms (a) thermo emf (b) thermocouple.

7. What is meant by a scale of temperature? On what does the definition of any particular scale depend?
8. The temperature of the surface of the sun is about  $6500^{\circ}\text{C}$ . What is the temperature (i) on Kelvin scale and(ii) on the
9. At what temperatures do the Celsius and Fahrenheit scales coincide?
10. At what temperature on the Fahrenheit scale will the reading be (i) the same as the reading on the Celsius scale (ii) double of the reading on the Celsius scale?

**Specific heats:**

11. What are the principles of calorimeter?
12. Distinguish between the specific heat of a gas at constant pressure and constant volume.
13. Define specific heat.
14. Give the reason why  $C_p > C_v$ .
15. Define Dulong and Petit's law.
16. Mention two uses of platinum coil (wire) in Nernst vacuum calorimeter.

**Thermal conductivity:**

17. Define the terms (a) water equivalent (b) thermal capacity.
18. Define coefficient of thermal conductivity. What are its dimensions?
19. Define temperature gradient and thermal conductivity.
20. Mention the CGS units of - Thermal conductivity, thermal diffusivity.
21. Define the terms - Thermal diffusivity, Thermal steady state.
22. Mention the SI units of -Thermal conductivity, Thermal diffusivity.
23. Give an expression for thermal conductivity and mention its dimensions.
24. The opposite faces of a metal plate of 0.2 cm thickness are at a difference of  $100^{\circ}\text{C}$  and the area of the plate is  $200\text{ Sq cm}$ . find the quantity of heat that will flow through the plate in one minute if  $k=0.2$  CGS units.
25. Calculate the masses of silver lead and aluminium which have the same thermal capacity as a liter of water. Their specific heats are 0.056, 0.031 and 0.22 respectively.

**5 Marks Questions**

**Thermometry:**

26. Give an account of the thermo electric thermometry and discuss the range, sensitivity and usefulness of some important thermocouples.
27. What do you understand by neutral temperature of a thermocouple? Explain.
28. Describe Seebeck effect and explain the terms neutral temperature and temperature of inversion.
29. Describe Callendar and Griffith's bridge for measuring the resistance of a platinum resistance thermometer at various temperatures.
30. When the temperature on the gas scale is  $80^{\circ}\text{C}$ , the corresponding temperature on the platinum scale is  $80.2^{\circ}\text{C}$  .What will be the temperature on the platinum scale corresponding to  $120^{\circ}\text{C}$  on the gas scale?
31. The resistance of the platinum wire of platinum resistance thermometer at the ice point is 5 ohms and at the steam point 5.93 ohms. The pressure exerted by the gas in a constant volume gas thermometer is (i) 100 cm of Hg at ice point (ii) 136.6 cm of Hg at

the steam point. When both the thermometers are inserted in the hot bath the resistance of the platinum wire is 5.795 ohms and the pressure of the gas is 131.11cm of Hg. Calculate Celsius temperature of the bath (i) on the platinum scale and (ii) on the gas scale.

32. If the platinum temperature, corresponding to 50<sup>0</sup>C on the gas scale is 50.25<sup>0</sup>C, what will be the temperature on the platinum scale corresponding to 150<sup>0</sup>C on the gas scale?
33. The resistance of the platinum wire at 0<sup>0</sup>C, 100<sup>0</sup>C and 444.6<sup>0</sup>C is found to be 5.5, 7.5 and 14.5 ohms respectively. The resistance of the wire at temperature t<sup>0</sup>C is given by the equation  $R_t = R_0(1 + \alpha t + \beta t^2)$ . Find the values of  $\alpha$  and  $\beta$ .
34. The emf of the thermocouple, one junction of which is kept at 0<sup>0</sup>C is given by  $E = at + bt^2$ . Determine the neutral temperature and temperature of inversion.

**Specific heats:**

35. Describe and explain Joly's steam calorimeter method for finding specific heat of gas at constant volume
36. Describe Nernst vacuum calorimeter and indicate briefly how it may be used to determine the specific heat at low temperature
37. Discuss Dulong and Petit's law and explain the variation of atomic heat of substance with temperature
38. Describe how the specific heat of a gas at constant pressure is determined accurately.
39. Describe the Regnault's method to find the specific heat of a gas at constant pressure.

**Thermal conductivity:**

40. A metal bar is heated at one end, Derive Fourier's differential equation for rectilinear flow
41. Of heat. Obtain an expression for the temperature distribution when the rod is open.
42. Describe Lee's method for determination of the thermal conductivity of a bad conducting material in the form of a disc.
43. Discuss rectilinear flow of heat along a bar of uniform cross section and show that in the steady state of a metal bar heated at one end  $\frac{d^2 \theta}{dx^2} = \mu^2 \theta$ .
44. Establish the standard Fourier differential equation for one dimensional flow heat when one end of a rod is heated.
45. Define thermal conductivity of substance. Derive an expression for it.
46. Define coefficient of thermal conductivity. What do you understand by a thermal steady state?

**10 Marks Questions**

**Thermometry:**

1. Give the principle, construction and working of a platinum resistance thermometer. Discuss its advantages over a thermoelectric thermometer.

**Specific heats:**

2. Describe and explain Joly's steam calorimeter method for finding specific heat of gas at constant volume

3. Describe Nernst vacuum calorimeter and indicate briefly how it may be used to determine the specific heat at low temperature
4. Discuss Dulong and Petit's law and explain the variation of atomic heat of substance with temperature

**Thermal conductivity:**

5. Define coefficient of thermal conductivity. Describe Forbes "method for determining the thermal conductivity of a metal rod.  
Or
6. Describe in detail Forbes method for finding the coefficient of thermal conductivity of a metal bar.

**UNIT -4: THERMODYNAMICS**

**2 Marks Questions**

**Heat engines:**

1. Distinguish between Otto engine & Diesel engine.
2. What is the heat engine? Mention the types of it.
3. Why the Diesel engines are not used in light vehicles.
4. What is the efficiency of Otto engine & Diesel engine?
5. State Carnot's theorem.
6. Draw the P-V diagrams that represent (i) Otto cycle and (ii) Diesel cycle.
7. Draw the entropy temperature diagram for Carnot's reversible engine.
8. State second law of thermodynamics?
9. What is temperature entropy (T-S) diagram? Write the expression for efficiency of a reversible Carnot's engine in terms of temperature.
10. Write the Clausius-Clapeyron's (Latent heat) equation and explain the terms.
11. State Clausius statement of second law of thermodynamics.
12. Explain the term entropy.
13. Is entropy scalar or vector? Write its S.I. unit.
14. What is T-S diagram?
15. What is the significance of T-S diagram?
16. What is the change in entropy in reversible and irreversible processes?
17. Write a short note on entropy as a measure of disorder.
18. What is effect of increase of pressure on the melting point of solid which contracts on melting?
19. What is effect of pressure on the boiling point of liquid?
20. Calculate the change in entropy when 1kg of water at 100°C is converted into steam at the same temperature. (Given: Latent heat of steam = 540 cal/gram)
21. Calculate the change in entropy when 10gram of ice at 0°C is converted into water at the same temperature. (Given: Latent heat of ice = 80 cal/gram)

**Thermodynamic potentials:**

22. Mention different types of thermodynamic potentials.
23. Write an expression for Enthalpy & Gibb's free energy.
24. Write an expression for internal energy & Helmholtz free energy.

25. Write the significance of thermodynamic potentials.

**Low temperature:**

26. Mention different methods of production of low temperature.

27. What is Refrigerator?

28. What is Joule-Thomson effect?

29. What do you mean by enthalpy?

**5 Marks Questions**

**Heat engines:**

1. Explain the working of Otto engine with neat labeled diagram.
2. Derive an expression for efficiency of Otto engine.
3. Explain the working of Diesel engine with neat labeled diagram.
4. Derive an expression for efficiency of Diesel engine.
5. Prove that efficiency of reversible engine is always greater than any other engine.
6. Prove that entropy always increases in irreversible processes.
7. Write a note on T-S diagram.
8. What do mean by entropy? Show that entropy remains constant in reversible process.
9. Calculate the change in entropy when 10gram of water at 60° C is mixed with 30gram of water at 20°C.
10. Calculate the change in entropy when 10grams of ice at 0°C is converted into steam at 100°C. (Given: Latent heat of steam = 540 cal/gram) .
11. Calculate the change in entropy when 0.1kg of water at 15°C is mixed with 0.16kg of water at 40°C. (Given: specific heat of water = 4200 J/Kg/K).
12. Find the efficiency of a Carnot's engine working between 400 K and 300 K. It absorbs 80 calories of heat. How much heat is rejected?
13. Calculate the change in entropy when 5 kg of water at 100 °C is converted into steam at the same temperature.(Given; Latent heat of steam=540calories/g)
14. Calculate the change in entropy, when 50 g of ice at 0°C is converted into water at the same temperature. (Given; Latent heat of steam=80calories/g)

**Thermodynamic potentials:**

15. Write a short note on thermodynamic potentials.
16. Using Maxwell's thermo dynamical relations deduce the Clausius-Clapeyron's equation. Hence explain the effect of pressure on boiling point of liquid.
17. Using Maxwell's thermo dynamical relations deduce the equation
$$C_p - C_v = T \left( \frac{\partial P}{\partial T} \right)_V \left( \frac{\partial V}{\partial T} \right)_P$$
 where symbols have their usual meaning.
18. Using Maxwell's thermodynamical relation, show that for a Vander Waal's gas
$$C_p - C_v = R \left( 1 + \frac{2a}{VRT} \right)$$
19. Use Maxwell's relation to obtain  $C_p - C_v = R$  for an ideal gas. Where  $C_p$  and  $C_v$  are molar specific heat at constant pressure and constant volume respectively.
20. Write down Maxwell's four thermodynamical relations and explain the terms.



21. Calculate under what pressure ice freezes at 272 K if the change in specific volume when 2kg of water freezes is  $90 \times 10^{-6} \text{ m}^3$  given Latent heat of ice  $= 3.36 \times 10^5 \text{ J/kg}$ .
22. Calculate the pressure required to make ice freeze at  $-1^\circ\text{C}$   $L = 79.6 \text{ Calories/g}$ , Specific volume of water at  $0^\circ\text{C} = 1000 \text{ cc}$ , specific volume of ice at  $0^\circ\text{C} = 1.091 \text{ cc}$  and one atmosphere  $= 1.0313 \times 10^6 \text{ dynes/cm}^2$ .
23. Calculate the change in Boiling point of water when the pressure is increased. By 1 atmosphere, B.P. of water  $100^\circ\text{C}$ . specific volume of steam  $= 1.671 \text{ m}^3$  and Latent heat of steam  $2.268 \times 10^6 \text{ J/kg}$ .
24. Calculate the change in the boiling point of water when the pressure of steam on its surface is increased from 1 atmosphere to 1.10 atmospheres. Given: Latent heat of water at  $100^\circ\text{C} = 537 \text{ cal/gram}$ ; volume of 1 gram of steam at  $100^\circ\text{C} = 1676 \text{ cm}^3$ .

**Low temperature:**

1. What is refrigerator? Explain the working of vapour compression machine.
2. Give the theory of porous plug experiment. Obtain conditions for heating and cooling of gas.
3. Explain vapour-compression machine with neat diagram.
4. What is Joule-Thomson's effect? Describe the Joule-Thomson's porous plug experiment.

**10 Marks Questions**

**Heat engines:**

1. Explain the working of Otto engine hence derive an expression for its efficiency.
2. Explain the working of Diesel engine hence derive an expression for its efficiency
3. What do you mean by entropy? Show that (i) entropy remains constant in reversible process and (ii) entropy increases in irreversible process.
4. Write a note (i) entropy (ii) T-S diagram

**Thermodynamic potentials:**

5. Derive Maxwell's thermodynamical relations.
6. Using Maxwell's thermodynamical relation, derive the following equations  
(i)  $C_p - C_v = R$   
(ii)  $C_p - C_v = R \left( 1 + \frac{2\alpha}{VRT} \right)$  for a Vander Waal's gas

**Low temperature:**

7. Describe porous plug experiment. What conclusions have been drawn from it? What is inversion temperature?
8. a) What do you mean by Joule-Thomson effect? Explain.  
b) What is refrigerator? Explain the working of vapour compression machine.

**UNIT -5: RADIATION**

**2 Marks Questions**

**Radiation:**

1. What is radiation pressure?

2. Write any two properties of thermal radiation.
3. State Stefan's law of radiation.
4. State Planck's law of radiation.
5. State Stefan's- Boltzmann's law of radiation.
6. State Wien's displacement law
7. State Rayleigh-Jean's law?
8. Write Planck's energy equation and explain the terms.
9. Explain emissive power and absorptive power.
10. List the advantages of Planck's law of radiation over the other laws.
11. Define solar constant.
12. What is total radiation pyrometer?
13. Distinguish b/w Stefan's law of Stefan's Boltzmann's law.
14. Who designed artificial black body?
15. What is pyrometer?
16. If Wein's constant  $K=0.3 \text{ cm K}$  calculate the temperature of the Sun whose radiation has maximum energy of wavelength  $5500 \text{ \AA}$ .
17. What is the wavelength of maximum intensity radiated from the surface of the temperature of  $3000^{\circ}\text{C}$  and Wein's constant is  $2.898 \times 10^{-3} \text{ mK}$ .
18. The surface temperature of the sun is  $6000\text{k}$  and Wein's constant is  $0.293\text{mK}$ . Calculate the maximum emission of wavelength of sun at given temperature.
19. Compare the radiant emittance of the black body at  $200 \text{ K}$  and  $2000 \text{ K}$  given that  $\sigma=5.6 \times 10^{-8} \text{ Wm}^{-2}\text{K}^{-4}$ .
20. The value of  $\lambda$  in a Black body radiation of a certain temperature in  $65 \text{ }^{\circ}\text{C}$ . Calculate  $\lambda$  When temperature of that body is doubled.
21. A black body radiates  $1000\text{J}$  of energy per solid when its temperature is  $300\text{k}$ ? What is the amount of energy radiated when its temperature is  $600\text{K}$

### ENERGY SOURCES

22. What do you mean by conventional energy sources?
23. What do you mean by non-conventional energy sources?
24. What are renewable energy sources?
25. What are non-renewable energy sources?

### 5 Marks Questions:

#### **Radiation:**

1. What is radiation pressure? State and explain Stefan's law of radiation.
2. What is black body? Explain the black body spectrum.
3. Deduce the Wein's displacement law.
4. Derive Stefan's law of radiation.
5. With neat diagram explain total radiation pyrometer
6. With neat diagram explain water flow pyreheliometer.
7. State Stefan's law explain the method to calculate the surface temperature of the sun using it.
8. Describe the experiment to determine the Solar constant.
9. Estimate the amount of heat radiated per second and the temperature of the sun given radius of the sun  $=6.958 \times 10^5 \text{ Km}$ , mean distance between sun and earth  $=148.48 \times 10^7 \text{ km}$  solar constant  $=1.39 \times 10^3 \text{ Wxm}^{-2}$  Stefan's constant  $=5.672 \times 10^{-8} \text{ W m}^{-2}\text{K}^{-4}$ .

- 10 Estimate the temperature of the Sun.
- 11 State and explain Wien's law and Rayleigh-Jeans law.
- 12 Write a note on solar radiation.

**Energy Sources:**

- 13 Explain conventional and nonconventional energy sources?
- 14 Explain renewable and nonrenewable energy sources?

**10 Marks Questions**

1. Describe with necessary theory the laboratory method to determine the Stefan's law.
2. Derive Planck's law of radiation.
3. Discuss the construction and working of Ferry's radiation pyrometer.
4. What is radiation pyrometer? Discuss the principal, construction and working of total radiation pyrometer
5. Give the laboratory method of determining Stefan's constant.
6. Discuss Wien's displacement law and Rayleigh- Jean's law. When Planck's law can be reduced to Wien's law and Rayleigh- Jean's law?
7. Estimate the Solar constant and the temperature of the Sun.

**ENERGY SOURCES**

8. a) What do you mean by energy source? b) Explain conventional and non-conventional energy sources. c) Explain renewable and non-renewable energy sources.



**DEPARTMENT OF PHYSICS**  
**BSc III Semester Question Bank**

**2 Marks(Theory)**

**Geometrical Optics:**

1. Give an expression for optical path
2. State Fermat's principle.
3. Explain 1<sup>st</sup> law of reflection using Fermat's principle.
4. Write Abbe's sine condition.
5. Define lateral magnification.
6. Write the expression for lateral magnification.
7. Write an expression for Helmholtz law of magnification.
8. State snell's law.
9. Define an equivalent lens.
10. Mention the cardinal points for a thick lens.
11. Define the second focal point of the lens.
12. Define principle points.
13. Define nodal point of the thick lens.
14. Write the expression for equivalent focal length of two thin lenses separated by a finite distance.
15. What are equivalent points.
16. Write expressions of translation and refraction matrix.
17. What is system matrix of an optical system?
18. What is aberration?
19. Mention different types of monochromatic aberrations.
20. What is meant by spherical aberration?
21. What is meant by chromatic aberration?
22. Mention the methods of minimizing the spherical aberration.
23. Explain the circle of least confusion.
24. How do you measure longitudinal and spherical aberration?
25. What is achromatism?
26. Write the condition for achromatism of two thin lenses in contact.
27. Write the condition for achromatism of two thin lenses separated by a distance.

28. What do you mean by longitudinal and lateral chromatic aberration?
29. Why is Huygens's eyepiece called a negative eyepiece?
30. Why is Ramsden's eyepiece called a positive eyepiece?
31. Compare Ramsden's eyepiece and Huygen's eyepiece.

**Interference:**

32. What is meant by interference of light?
33. What is meant by division of Wave front?
34. What is meant by division of Amplitude?
35. What are coherent sources?
36. Mention the conditions for sustained interference.
37. What is Fresnel's biprism?
38. What is monochromatic light?
39. Write the expression for thickness of a thin transparent plate by Fresnel's Biprism experiment.
40. When Newton's rings are formed due to reflection of light the central part is dark. Explain why?
41. Write the expression for the path difference for the bright fringe in case of wedge shaped thin film.
42. What are Newton's rings?
43. When the thin films such as oil on water, soap bubbles are illuminated, colors are obtained. Why?
44. What is an interferometer?
45. Mention two uses of Michelson's interferometer.

**Diffraction:**

46. What is diffraction of light? And who discovered it?
47. What is Fresnel diffraction?
48. What is Fraunhofer diffraction?
49. What do you understand by zone plate?
50. Compare zone plate with convex lens.
51. What are half period zones?
52. What is diffraction grating?
53. Define Resolving power of grating.
54. State Rayleigh's criterion for limit of resolution.
55. Define resolving power and limit of resolution of an optical instrument.
56. Distinguish between prism and grating spectra.
57. Distinguish between interference fringes and diffraction fringes.
58. Define R.P of prism & write the expression for it.

### **Polarization:**

59. What is meant by polarization? Explain.
60. Which property of light is justified by polarization?
61. Mention the methods of producing plane polarized light.
62. Name two commonly used devices which use polarised light.
63. State malus law.
64. What is double refraction? Explain.
65. Write a note on retardation plates/ retarders.
66. What is a quarter wave plate?
67. What is a half wave plate?
68. What are uniaxial crystals? Mention an example.
69. Write the expression for the thickness of a half wave plate
70. Write an expression for thickness of quarter wave plate.
71. What is path difference and phase difference produced in half wave plate?
72. What is path difference and phase difference produced in quarter wave plate?
73. What is meant by circularly polarized light?
74. What is meant by elliptically polarized light?
75. What are principle refractive indices of a doubly refracting crystal?
76. What are positive crystals? Mention an example.
77. What are negative crystals? Mention an example.
78. Distinguish between positive crystal & negative crystal
79. Write a note on optical activity.
80. What are dextrorotatory and laevorotatory substances? Mention an example of each.

### **Astrophysics:**

81. What is astrophysics?
82. Write the physical properties of stars.
83. Explain the magnitude of a star.
84. Define apparent and absolute magnitude.
85. Establish the relation between absolute and apparent magnitude.
86. Define luminosity of the star. Establish its relation with brightness.
87. Analyze the masses of various stars on the HR diagram.
88. Analyze the radii of various stars on the HR diagram.
89. If a star has an apparent magnitude equal to its absolute magnitude, how far away is it in parsecs? In light-years?

90. What is the relation between colour and temperature of the star?
91. Write the relation between magnitudes of the star and distance.
92. Why is there a main sequence?
93. Explain: A massive star have lower life span.
94. What is Chandrasekhar's limit?
95. What are white dwarfs?
96. What are neutron stars?
97. What are black holes?
98. Define stellar photometry.

### **2 Marks(Problems)**

#### **Geometrical Optics:**

99. Calculate the equivalent focal length of two thin lenses of focal lengths 0.50m and 0.2m kept at a distance of 0.3.
100. The focal length of two lenses forming an achromatic doublet are 1.5m & 1 m respectively what is the ratio of their dispersive powers.

#### **Interference:**

101. In moving the mirror  $M_1$  of Michleson's interferometer through a distance of 0.4220mm, 1500 fringes are counted calculate the wave length of the light.
102. The diameter of 4<sup>th</sup> ring in Newton's ring experiment is 0.18mm, Calculate diameter of 16<sup>th</sup> dark ring?

#### **Diffraction:**

103. Find the resolving power of a prism having base of 5 cm and  $d\mu/d\lambda = 1200$ .
104. Calculate the resolving power of a diffraction grating in the second order having 10000 lines.
105. What is the radius of first zone in a zone plate of focal length 0.40m for the light of 400 nm?
106. Calculate the thickness of a half wave plate of quartz for which  $\mu_o = 1.544$  &  $\mu_e = 1.553$ , for a light of wave length 5893Å
107. In the first order diffraction with a light of wave length 6000Å the diffraction angle for a grating is  $30^\circ$  find the number of lines per cm of the grating

108. Calculate the thickness of the half wave plate. Given  $\lambda=5000 \text{ \AA}$   $\eta_0=1.544$  &  $\eta_e=1.553$

**Astrophysics:**

109. Calculate the distance of star in km if the parallax,  $p= 0.023$ arcseconds.  
110. If absolute magnitude of sun is +5.0, find its apparent magnitude.  
111. If a star has a parallax of 0.050 arcsecond, what is its distance in pc. and l. y.?

**5 marks(Theory)**

**Geometrical Optics:**

1. State Fermat's principal.. Prove second law of reflection from Fermat's principle .
2. Prove Snell's law of refraction from Fermat's principle.
3. Derive Lagrange & Helmholtz relation.
4. Define lateral magnification & derive the expression for lateral magnification.
5. State the sign conventions in the case of spherical reflecting surfaces.
6. Obtain Abbe's Sine Condition.
7. Derive Helmholtz's relation as used for a number of coaxial refracting surface.
8. Explain cardinal points with reference to the coaxial system.
9. What are principal points & principal planes? Show that the principal planes are the planes of unit linear magnification.
10. Draw a neat diagram to represent the cardinal pts of two thin lenses separated by a distance .
11. What are nodal points & nodal planes? Give their properties.
12. Mention the expressions of focal length and cardinal points of a thick lens.
13. Deduce equations for image plane and magnification of an optical system by matrix method.
14. What is spherical aberration for a lens? Describe the methods of minimizing spherical aberration in brief.
15. Deduce the condition for minimum spherical aberration by using two plano-convex lenses.
16. Obtain an expression for lateral chromatic aberration.
17. What is achromatism? Derive the conditions of achromatism of two thin lenses separated by a distance.
18. Describe with relevant theory the achromatic combinations of two lenses in contact and hence mention the conditions.



19. Distinguish between Ramsden and Huygen eye- pieces.
20. Describe the construction and working of Ramsden's eyepiece.
21. Describe the construction and working of Huygen's eyepiece.

**Interference:**

22. Discuss the interferences phenomenon for wedge-shaped film.
23. Derive the expression for fringe width in the wedge shaped film.
24. How do you determine the wavelength of light using Fresnel's Biprism?
25. Explain stoke's treatment of phase change to reflection and refraction.
26. Explain Newton's ring's produced due to reflection.
27. Describe Michelson's interferometer with a neat diagram.
28. Determine the wavelength of light by Newton's rings.
29. In Newton's rings experiment, obtain the conditions for bright and dark rings.
30. Describe the construction of fabry perot interferometer with labeled diagram.
31. Describe the principle and working of fabry perot interferometer.
32. Describe the construction of Michelson's interferometer with neat labeled diagram.
33. Explain Michelson's interferometer is used for determination for wavelength of monochromatic source of light.
34. Explain how Michelson's interferometer is used to determine the difference in wavelength of two close lines.

**Diffraction:**

35. Discuss Fresnel's theory of half period zone in relation to plane wave front.
36. Discuss Fraunhofer diffraction due to double slit.
37. Show that the amplitude due to a complete wave front of a point is half the what would be caused by the first zone.
38. Distinguish between Fresnel and Fraunhofer diffraction.
39. What is diffraction of light? How did Fresnel explained diffraction based on his assumption .
40. Give the comparison of a Zone plate & a convex lens.
41. Discuss analytically the distribution of intensity in the diffraction pattern due to a single slit.
42. What is dispersive power of a grating and deduce an expression for it?
43. Compare between prism spectra & grating spectra.

44. Derive an expression for the angular dispersion of a plane diffraction grating.

### **Polarization:**

45. State and explain Malu's law.
46. Discuss the difference between positive and negative crystal.
47. Describe Huygen's explanation of double refraction in uniaxial crystal.
48. Explain Huygen's theory of light in negative crystal when optic crystal is in the plane of incidence and inclined at an angle to the refracting surface.
49. Explain Huygen's wave theory of light when optic axis is in the plane of incidence and perpendicular to the refracting surface.
50. Describe Huygen's wave theory in negative crystal when optic axis is in the plane of incidence and parallel to the refracting surface.
51. What is quarter wave plate? Arrive at an expression for its thickness.
52. What is half wave plate? Arrive at an expression for its thickness.
53. What is circularly polarized light? How is it produced?
54. How can elliptically polarized light be produced? Explain.
55. Give the analytical treatment of circularly polarized light.
56. Give the analytical treatment of elliptically polarized light.
57. Explain Fresnel's theory of optical rotation.
58. Distinguish between circularly polarized light and unpolarized light.
59. What is double refraction? Describe how Huygen explained it.
60. Write a note on optical activity.
61. Write the assumption made by Fresnel to explain the phenomenon of optical rotation .

### **Astrophysics:**

62. Write a note on HR diagram and its interpretation with mass and radii.
63. Write a note on birth stars.
64. What are pulsars? Write a note on formation of neutron stars.
65. What is novae and supernovae? Write a note on formation black holes.
66. Explain the energy source of Sun.
67. Write a note on solar interior.
68. Write a note on features of photosphere chromospheres and corona.
69. What are sunspots? What produces the granulation on the surface of the Sun?

70. Explain the working of astronomical photometer with neat labeled diagram.
71. Write a note on reflecting telescopes.
72. Compare the advantages and disadvantages of reflecting and refracting telescopes.

### **5 Marks(Problems)**

#### **Geometrical Optics:**

73. Two thin convex lenses of focal lengths 0.06m and 0.02m are placed 0.04m apart. Calculate equivalent focal length, the position of principal and focal points.
74. A concave spherical surface of radius 1m separates two media of R.I.=  $\frac{3}{2}$  and  $\frac{4}{3}$ . An object is kept in first medium at a distance of 0.3m from the surface. Calculate the position of image.
75. A convex surface of radius 0.4m separates two media of R.I.=  $\frac{4}{3}$  and  $\frac{3}{2}$ . An object is kept in first medium at a distance of 0.2m from the surface. Calculate the position of image.
76. A glass dumbbell of length 0.5m and R.I. 1.5 has ends of 0.05m radius of curvature. Find the position of the image due to refraction at one end only, when the object is kept in air at a distance of 0.2m from the end of dumbbell along the axis.
77. A convex lens of focal length 0.05m and a concave lens of focal length 0.07m are placed 2.5cm apart. Calculate the equivalent focal length and the position of cardinal points.
78. Two thin lenses of same material separated by a distance have an equivalent focal length of 0.5m. the combination satisfies the conditions for minimum spherical aberrations and achromatism. Find the focal length of the lenses and their separation.

#### **Interference:**

79. In a biprism experiments with sodium light of wave length 5893 Å. The micrometer reading is 2.32 mm. When the eyepiece is placed at a distance of 100 cm from the source. If the distance between two virtual sources is 2 cm. Find the new reading of the micrometer if the eye piece is moved such that 20 fringes cross the field of view.
80. In a biprism experiment, a biprism of angle 10 and refractive index 1.5 is placed at a distance of 0.4 m from the slit and 0.6 m from the screen. Calculate the fringe width if light of 599.6 nm is used.
81. In a biprism experiment with sodium light bands of width 0.0195 cm are

- observed at 100 cm from the slit. On introducing a convex lens 30 cm away from the slit, two images of the slit are seen 0.7 cms. apart at 100 cms distance from slit. Calculate the wavelength of sodium light.
82. In Newton's ring experiment, find the radius of curvature of the lens in contact with the glass plate, for the light of wave length  $6000 \text{ \AA}$ . The diameter of 5th dark ring in the reflected pattern is 5.2 mm.
83. In a Newton's rings experiments the diameters of 5<sup>th</sup> & 15<sup>th</sup> rings are  $0.336 \times 10^{-2} \text{ m}$  and  $0.590 \times 10^{-2}$  resp find the radius of curvature of plano convex lens, if wave length of light used is  $5890 \text{ \AA}$ . A transparent plate of thickness  $10^{-3} \text{ cm}$  is placed in the path of one of the interfering beams of a biprism experiment using light of wave length  $5000 \text{ \AA}$  if the central fringe shifts by a distance equal to width of 10 fringes. Calculate R.I of the plate.
84. In an experiment with michelson's Interfereometer to distance traveled by movable mirror for two successive positions of maximum intensities was 0.2845mm if the mean wave length of two components of sodium D line is  $5893 \text{ \AA}$ . Calculate to difference between wave length.

### **Diffraction:**

85. A light of wave length  $5000 \text{ \AA}$  is incident normally on a plane transmission grating of width 0.03 m and 1500 lines. Find the angle of diffraction in the first order.
86. A zone plate a radius of first ring 0.05 cms. If light of wave length  $5000 \text{ \AA}$  falls on the plate, find where the screen must be placed so that light is focused for bright spot.
87. Calculate the minimum number of lines per cm in 2.5 cms wide grating which will just resolve the sodium lines ( $5890 \text{ \AA}$  and  $5896 \text{ \AA}$ ) in the 2nd order spectrum.
88. Calculate the minimum thick ness of the base of a prism which will just resolve the  $D_1$  and  $D_2$  lines of sodium. Given  $\mu$  for wave length  $6563 \text{ \AA} = 1.6545$  and for wave length  $5270 \text{ \AA} = 1.6635$ .

### **Polarization:**

89. Two polarizing sheets have their polarizing direction parallel so that the intensity of the transmitted light is maximum. Through what angle must either sheet be turned so that the intensity become one half the initial value.
90. Two Nicols are first crossed and then one of them is rotated through  $60^\circ$ . Calculate the percentage of incident light transmitted.

91. Calculate the least thickness and next two successive thickness of a quarter wave plate of quartz for light of wavelength  $5893 \text{ \AA}$  and  $n_o = 1.544$  and  $n_e = 1.553$ .
92. In case of negative crystal calculate the thickness of Quarter-wave plate and half wave plate for the light of wave length  $5869 \text{ \AA}$ . Given  $\mu_o = 1.551$   $\mu_e = 1.451$ .

### 10 Marks(Theory)

#### Geometrical Optics:

1. Derive the expression for reflection of light at a spherical surface applying format principle.
2. Derive the exp for the equivalent focal length & position of principle points & focal points of a coaxial system of two their lenses separated by finite distance.
3. Obtain system matrix for thick and thin lenses and hence deduce thin lens formula.
4. Obtain expressions for longitudinal chromatic aberration taking an object at infinity and at a finite distance.
5. Obtain the conditions of achromatism for the combination of two lens in contact and separated by a distance.
6. What is an ocular? Explain Ramsden and Huygen's eye-pieces.
7. Give the construction & working of huygen's eyepiece with necessary calculations indicate in the diagram the position of the cardinal points.

#### Interference:

8. Based on Fresnel's assumption how rectilinear propagation of light is explained.
9. Describe Fresnel's biprism experiment to determine the wavelength of monochromatic light.
10. Derive the condition for constructive and destructive interference in case of a thin film for reflected light.
11. Derive the conditions for constructive and destructive interference in case of a thin film for transmitted light.
12. Explain the formation of Newton's rings obtain an expression for the Wavelength of monochromatic light.
13. Describe the construction and working of Michelson's interferometer. How do you determine the wave length of monochromatic light.

14. Describe the construction and working Michelson's interferometer. Explain the nature of circular and straight fringes.
15. In case of thin films , derive the condition for maxima & minima due to interference of reflected light.
16.
  - a. Explain the construction & working of Michelson's interferometer
  - b. How it is used to determine  $(\lambda_1 - \lambda_2)$ ?
17. Describe the construction & working of fabry perot interferometer .

### **Diffraction:**

18. What is Zone plate? Explain the theory of zone plate ( obtain the expression for focal length of zone plate ).
19. Describe the construction of zone plate. Show that the zone plate has different foci for different wavelengths.
20. Give Fresnel's theory of half period zones. How it is used to explain rectilinear propagation of light?
21. What is plane transmission grating? Discuss its theory and derive the condition for secondary maxima & minima.
22. Define resolving power and dispersive power of plane diffraction grating. Obtain expression for these in case of plane diffraction grating.
23.
  - a. Define resolving power of an optical instrument.
  - b. Derive an expression for resolving power of a prism.
24. Discuss the Fraunhofer type of diffraction produced by a narrow single slit of width 'a' and illuminated by a monochromatic light of wavelength  $\lambda$ .
25. Discuss fraunhofers diffraction pattern due to a single slit. Find the exp for the width of the central maxima .
26. Give the complete account of the phenomenon & relevant theory of diffraction at 'n' parallel slits.
27. Mention the difference between Fresnels and Fraunhoffer diffraction. Explain the diffraction pattern at single slit.
28. Explain the terms half period zones in relation to plane wave font show that the amplitude due to a complete wave font at a pt is half of what would because by the first half period eliminate zone.

### **Polarization:**

- 29.

- a. State and explain Malu's law.
  - b. Distinguish between positive and negative crystal.
- 30.
- a. Give the Huygen's theory of double refraction
  - b. Distinguish between positive crystals & negative crystals .
31. Discuss the phenomenon of double refraction based on Huygen's principle of double refraction in (i). optic axis parallel (ii). Perpendicular to the refracting surface.
32. What is optical activity give Fresnel's theory of rotational polarization ?
- 33.
- a. Explain the Fresnel's theory of rotatory polarization.
  - b. Distinguish between positive and negative crystals.
34. What are retarders? Obtain the expression for thickness of (i) half wave plate. (ii) quarter wave plate.
35. Give the detail analysis of unpolarized, plane, circularly and elliptically polarized light.
36. What are quarter wave plate & half wave plate? Write the expression for thickness of the quarter wave plate & half plate for negative & positive crystal.
37. Give the analytical treatment for production of Circularly and Elliptically polarized light.

### **Astrophysics:**

38. Explain the properties of stars.
39. The apparent magnitude of a star is observed to be +3.3 and its parallax is 0.025 arcseconds. Find the absolute magnitude of the star. Compare the luminosity of this star with sun.
40. Write a note on evolution of stars.
41. What is Chandrasekhar's limit? Explain death of stars.
42. Discuss the structure of the sun from core to photosphere with diagram.
43. What is CCD astrophotography? Write a note on refracting and reflecting telescopes with diagrams.

**Note: More questions may also be added.**



**DEPARTMENT OF PHYSICS**

**SEMESTER- IV(PAPER:PH-411)**

**Unit-1:ELECTROSTATICS**

**2 Marks**

1. Define dielectric polarization.
2. Write the relation connecting P, E and D for a dielectric medium.
3. If a soap bubble is given a negative charge then what happens to its radius?
4. Mention the factors on which electric displacement depends.
5. What is the value of the electric field at a point inside a charged conducting sphere?
6. Define dielectric constant
7. Write the unit for electric displacement D .
8. What are the conditions that are to be satisfied to find an electrical image?
9. Write the unit for polarization P.
10. What are dielectrics? In what respects do they differ from conductors?
11. Explain electric displacement (D).
12. Explain susceptibility ( $\chi$ ).
13. Mention the boundary condition to be satisfied by D and E at the interface of two dielectric media?
14. Give the expression for force between charges in a dielectric medium.
15. Explain the significance of electrical images.
16. Point out the limitations of Clausius -Mossotti equation
17. Give the relation between polarization and induced surface charge density
18. What is an electrical image?
19. What are the conditions that must be satisfied in finding an electrical image?
20. Calculate the dielectric constant of the material when inserted in parallel plate capacitor of size 10mm X10mm and distance between plates is 2 mm gives capacitance of  $10^{-9}$  F.



21. The permittivity of a diamond is  $1.46 \times 10^{-10} \text{ C}^2/\text{Nm}^2$ . Determine the dielectric constant and electrical susceptibility.
22. A charge of  $2\mu\text{C}$  is placed at a distance of  $0.3\text{m}$  from the centre of the sphere of radius  $0.1\text{m}$ . Calculate the magnitude of the electrical image.
23. The dielectric constant of a medium is 2. Electric field in the dielectric is  $10^6 \text{ Vm}^{-1}$ . Calculate electric displacement.

### **5 Marks**

1. Give the Cavendish's proof of inverse square law in electrostatics.
2. What are polar molecules and non-polar molecules? Explain the behavior of a dielectric in an electric Field.
3. Explain Gauss law in dielectrics and obtain the relation between induced charge and dielectric constant.
4. Derive the relationship between electric displacement  $D$ , polarization  $P$  and electric field  $E$ .
5. What are polar molecules and non-polar molecules? Obtain the relation between dielectric susceptibility and dielectric constant.
6. Obtain an expression for the mechanical force on the surface of a charged conductor.
7. Explain the terms electric displacement and electric polarization. Write the relation connecting them.
8. Mention the expression for electrostatic pressure on the surface of charged conductor. Obtain the expression for excess pressure inside the soap bubble due to electrification.
9. Find the polarisation in a dielectric material with relative permittivity of 2.8 if the electric displacement is given by as  $D= 3 \times 10^{-7} \text{ C/m}^2$
10. Four grams of gold is beaten into a thin leaf of  $1\text{sq m}$ . A small is cut of from this and placed upon the conductor. Calculate the charge density required by the conductor so that the piece of the gold is just lifted up.
11. What charge must there be upon soap bubble of radius  $1.5 \text{ cm}$ , if air pressure is same inside and outside bubble? The surface tension of soap bubble is  $27$ .
12. A sphere of diameter  $0.05 \text{ m}$  is charged to a potential of  $1000 \text{ volts}$ . Calculate the outward pull per unit area.

### **10 Marks**

1. Obtain an expression for the mechanical force on the surface of a charged conductor. Hence derive an expression for the energy density of the electrostatic field.

2. Define an electrical image. Derive the expression for the electric intensity at a point on an infinite plane conducting surface which is earthed. Find the force of attraction between the conducting plane and the charge.
3. Derive expression for electric intensity and surface density of charge at a point on the surface of an earthed conducting sphere using electrical image.
4. Derive Clausius-Mossotti equation for molecular field in a dielectric.
5. Derive the boundary conditions for electric displacement (D) and electric field (E) at a surface separating the two dielectric media.
6. Obtain an expression for the charge on the soap bubble if the pressure inside the bubble is same as that of outside.

## **UNIT-2:CURRENT ELECTRICITY**

### **2 Marks**

1. What is Lorentz force ?
2. State Ampere circuital law.
3. Give the statement of Biot savart law.
4. What is the principle Helmholtz galvanometer?
5. What is the condition to get uniform magnetic field over a region in case of Helmholtz galvanometer?
6. Define magnetic induction and magnetic flux.
7. Explain about Lorentz force on a moving charge.
8. Write an expression for magnetic induction at a point due to a straight conductor carrying current.
9. Write an expression for magnetic induction due to toroid.
10. Write an expression for magnetic induction at a point inside the long solenoid.
11. Write an expression for magnetic induction on the axis of a circular coil carrying current.
12. What are the advantages of Helmholtz galvanometer over the tangent galvanometer?
13. what is meant by damping?
14. what is “dead beat” galvanometer?
15. what is figure of merit of galvanometer?
16. Write the condition for a moving coil galvanometer to be ballistic.
17. Write the condition for a moving coil galvanometer to be deadbeat.

18. Define Mutual inductance. Mention its SI unit.
19. Define current reduction factor.
20. Define ballistic reduction factor.
21. What is Logarithmic decrement?
22. Define Voltage sensitivity.
23. Define Charge sensitivity.
24. Give the relation between Charge sensitivity and Current sensitivity.
25. Which quantities can be measured using Ballistic galvanometer?
26. An infinitely long conductor carries the current of 2 ampere , calculate the magnetic field at a distance of 2m from the conductor.
27. A circular coil of 10 turns and radius 0.14m carries a current of 2.8 ampere. Find the magnetic field at the centre of coil.
28. A solenoid of 1200 turns is wound uniformly in a single layer on a glass tube 2 m long. Find the magnetic induction at the centre of a solenoid when a current of 2 A flows through it.
29. The successive throws of a ballistic galvanometer are 25 cm and 24.8 cm. what is its logarithmic decrement?
30. A coil has an inductance of 0.02 Henry. Determine the emf induced in it when the current is changing at the rate of 200 A/S.
31. The current sensitivity of a ballistic Galvanometer is  $2.2 \times 10^{-9}$  Amperes for a deflection of 1mm on a scale kept at a distance of 1m. Calculate the charge sensitivity of the galvanometer if time period of the coil is 6.2 Seconds.
32. The successive throws in a Ballistic-galvanometer are 20cm and 19.8cm on the same side. Find its logarithmic decrement.
33. The successive throws on the same side of the mean position for an oscillating coil are 25, 24.9 and 24.8 cm. Calculate the logarithmic decrement?

### **5 Marks**

1. State and prove Ampere circuital law.
2. Mention the expression for magnetic field on the axis of a circular coil carrying current and discuss the special cases.
3. Describe the principle and working of a Helmholtz galvanometer.
4. Derive an expression for the flux density at a point inside long solenoid.
5. Derive an expression for 'B' due to infinitely long straight current carrying conductor.

6. Mention the conditions for moving coil galvanometer to be ballistic and dead- beat
7. What is logarithmic decrement? Hence obtain damping correction in terms of logarithmic decrement of ballistic Galvanometer.
8. Give the correction for Damping in Ballistic Galvanometer.
9. A straight infinitely long conductor carries a current of 2 amps. Determine the magnetic field due to it at a distance of 0.01m from it. Calculate the magnetic flux through a surface area  $1 \times 10^{-6} \text{ m}^2$  of a co-axial cylinder at  $1 \times 10^{-2} \text{ m}$  from conductor the surface being normal to the magnetic field.
10. A circular coil has a radius of 0.1m and a number of turns of 50. calculate the magnetic induction at a point (i) on the axis of the coil and distance 0.2m from the centre (ii) at the centre of the coil, when a current of 0.1A flows in it.
11. Each of the coils of a Helmholtz galvanometer contains 50 turns of wire of mean radius 0.2m. When a current of 0.1A is passed through the coil, a deflection of  $45^\circ$  is obtained . calculate the horizontal component of earth's field.
12. A Helmholtz galvanometer having coils each of 25 turns and radius 0.1m. produces deflection of  $45^\circ$  when a current flows through it. Find the current when horizontal component of earth's field is  $0.3 \times 10^{-5} \text{ T}$ .
13. The successive deflections to the right and left of the mean position in case of a ballistic galvanometer are found to be 20, 19.9, 19.8 cm calculate deflection without damping.
14. The current sensitivity of a ballistic galvanometer is  $2.2 \times 10^{-9} \text{ A}$ . for a deflection of 1 mm on a scale kept at a distance of 1 m. If the charge sensitivity of the galvanometer is  $2.17 \times 10^{-9} \text{ coulomb mm}$ . Calculate the time period of the coil.
15. Calculate the value of the Torque on a current loop placed in a uniform magnetic field.
16. A capacitor charged up to 2 volts is discharged through a ballistic galvanometer having period of 12 sec. and current sensitivity  $2.2 \times 10^{-8} \text{ amp/cm}$ . If the first and eleventh throws of galvanometer are 9.6cm and 8cm respectively, calculate the capacitance of the capacitor.

### **10 Marks**

1. State Biot –Savart law. Deduce an expression for the magnetic field due to a current flowing in a straight conductor of infinite length.
2. Give the principle, theory and working of Helmholtz galvanometer.

- Obtain an expression for magnetic field inside the solenoid using Ampere's circuital law.  
State and prove Ampere's circuital law. Obtain an expression for magnetic field due to toroid using Ampere's circuital law.
- Give the construction of a moving coil ballistic galvanometer and deduce a formula for the quantity of charge flowing through it.
- How will you determine the capacity of a condenser by absolute method? Give necessary theory.
- Explain how (a) Charge sensitivity and (b) absolute capacitance of a Capacitor is determined using a ballistic galvanometer.
- Describe the method to measure the mutual inductance between two coils by direct method with necessary theory.

### **Unit-3:THERMOELECTRICITY**

#### **2marks**

- What is Seebeck effect?
- What is thermo electric series?
- State the law of intermediate temperature.
- State the law of intermediate metals.
- What is thermoelectric curve & what it gives?
- Define thermoelectric power and mention its expression.
- Define temperature of inversion and mention its dependent factor.
- What is peltier effect?
- Define peltier co efficient.
- What is Thomson effect? Define Thomson Co efficient.
- What is Tait diagram?
- What are the uses of Tait diagrams?

#### **5 Marks**

- State and explain Seebeck effect.
- State and explain laws of thermoelectricity.
- Write a note on thermoelectric series.
- Deduce,  $T_N = \frac{t_1+t_2}{2} = \frac{-a}{2b}$ .
- Show that,  $T_i = 2T_N - t_1$ .
- Explain thermoelectric curve.
- What is Peltier effect? Explain.

8. Explain thermodynamics of Peltier effect.
9. What is Thomson effect? Explain.
10. Establish the relation between Seebeck, Peltier and Thomson emfs.
11. Distinguish between Peltier and Joule's effects.
12. Show that,  $e_{t_1}^{t_2} = (t_2 - t_1)\{a + b(t_2 + t_1)\}$ .
13. Thermoelectric Potential of a thermocouple is  $6\mu\text{V}$  at  $100^\circ\text{C}$  and is  $15\mu\text{V}$  at  $0^\circ\text{C}$ . Find the emf between  $50^\circ\text{C}$  and  $150^\circ\text{C}$ .
14. Thermoelectric Potential of a thermocouple is  $6\mu\text{V}$  at  $100^\circ\text{C}$  and is  $15\mu\text{V}$  at  $0^\circ\text{C}$ . Find the emf between  $0^\circ\text{C}$  and  $100^\circ\text{C}$ .
15. Thermoelectric Potential of a thermocouple is  $15\mu\text{V}$  at  $0^\circ\text{C}$  and is  $6\mu\text{V}$  at  $100^\circ\text{C}$ . Find the emf between  $100^\circ\text{C}$  and  $200^\circ\text{C}$ . Also find neutral temperature and temperature of inversion when the temperature of cold junction is  $20^\circ\text{C}$ .
16. Thermoelectric Potential of Fe is  $17.5\mu\text{V}/^\circ\text{C}$  at  $0^\circ\text{C}$  and  $5\mu\text{V}/^\circ\text{C}$  at  $250^\circ\text{C}$  and TEP of Cd is  $3\mu\text{V}/^\circ\text{C}$  at  $0^\circ\text{C}$  and  $15\mu\text{V}/^\circ\text{C}$  at  $300^\circ\text{C}$ . Calculate the neutral temperature and emf of Fe-Cd couple between  $0^\circ\text{C}$  and  $100^\circ\text{C}$ .
17. Thermoelectric Potential of Fe is  $17.34\mu\text{V}/^\circ\text{C}$  at  $0^\circ\text{C}$  and  $12.47\mu\text{V}/^\circ\text{C}$  at  $100^\circ\text{C}$  and TEP of Cu is  $1.36\mu\text{V}/^\circ\text{C}$  at  $0^\circ\text{C}$  and  $2.31\mu\text{V}/^\circ\text{C}$  at  $100^\circ\text{C}$ . Calculate the emf of Fe-Cu couple between  $0^\circ\text{C}$  and  $100^\circ\text{C}$ .
18. The emf of a thermocouple between  $0^\circ\text{C}$  and  $t^\circ\text{C}$  is  $e = 1.36 \times 10^{-5} t - 1.8 \times 10^{-8} t^2$ . Determine emf between 0 and  $100^\circ\text{C}$ , emf between 100 and  $200^\circ\text{C}$ , neutral temperature, peltier co efficient at  $100^\circ\text{C}$  and Thomson Co efficient and temperature at  $50^\circ\text{C}$ .

### **10 Marks**

1. Deduce ,  $\pi = T \frac{d\varepsilon}{dt}$  and  $\sigma = T \frac{d\varepsilon^2}{dt^2}$ .
2. Explain Tait diagram of a thermocouple and its uses to determine Peltier and Thomson co-efficients and emfs.
3. Explain Tait diagram of an element and its uses to determine Peltier and Thomson co-efficients and emfs.

## **Unit-4:A.C AND TRANSIENT CIRCUITS**

### **2 Marks**

1. Through what angle does complex vector rotates when it is multiplied with operator  $j$ ?
2. Mention the expression for instantaneous value of a.c. current.
3. Give the condition under which electric resonance occurs.
4. What is electrical resonance?
5. What is power factor of an ac circuit?
6. Define quality factor (Q).
7. Why series resonance circuit is called an acceptor circuit?
8. Why parallel resonance circuit is called as rejecter circuit?
9. Explain voltage magnification in series LCR circuit.
10. Mention the expression for quality factor (Q) in terms of band width.
11. What is meant by time constant in RL circuit?
12. What is time constant of the RC circuit?
13. Give the nature of Curves for growth & decay of charge in a condenser through a resistance .
14. Give the nature of Curves for growth and decay of current in RL circuit.
15. Calculate the time constant of RL circuit with  $R=10M\Omega$  and  $L=5mH$ .
16. A condenser of  $1\ \mu F$  is first charged and then discharged through a resistance of  $1M\Omega$ . calculate the time constant in which the charge of the condenser will fall to 63.2 % of initial value.
17. If the charge on a capacitor of capacitance  $2\mu F$  is leaking through a high resistance of  $100\ M\Omega$  is reduced to half of its maximum value, calculate the time of leakage.

### **5 Marks**

1. Write the expression for the impedance of a series LCR circuit with the meaning of each symbol used. Why is it called an acceptor circuit?
2. Distinguish between series and parallel resonance circuits.
3. Give the theory of growth of current in RL circuit.
4. Give the theory of decay of charge in a condenser through a resistance.
5. Describe with full theory the method of measuring high resistance by method of leakage.
6. An AC circuit containing an impedance of  $10mH$  and a capacitor of  $1\mu f$  and a resistance of  $100\Omega$  in series a rms voltage  $100V$  is applied. Calculate the frequency at which the circuit will be in resonance and find the value of current.
7. A series circuit has an inductance of  $2mH$  a capacitance of  $2mf$  and resistance of  $100\Omega$ . Find the resonant frequency of circuit.

8. An rms voltage 100V is applied to a AC circuit containing an impedance of 10mH and a capacitor of  $1\mu\text{f}$  and a resistance of  $100\Omega$  in series. Calculate the frequency at which the circuit will be in resonance and find the value of current.
9. A capacitor is charged to a certain potential by a battery through a resistance of  $3\text{M}\Omega$ . If it reaches  $2/3$  of its final potential in 0.6 second, calculate its capacitance.
10. A series combination of a capacitor & a resistor is connected to a steady source of 200 v. The P. d. across the resistor rises from 0 to 80 v in 5 sec. calculate the time constant of the circuit.
11. An e.m.f 10 volts is applied to a circuit having a resistance of 10 ohms and an inductance of 0.5 Henry. Find the time required by the current to attain 63.2 % of its final value. What is the time constant of the circuit?
12. An inductance of 500 mH and a resistance of 5 ohms are connected in series with an e.m.f of 10 volts, find the final current. If the cell is removed and the two terminals are connected together, find the current after (i) 0.05 sec and (ii) 0.2 sec
13. A capacitor is charged by DC supply through a resistance of  $2\text{M}\Omega$  if it takes 0.5 seconds for the charge to reach three quarters of its final value, what is the capacitance of the capacitor?
14. A capacitor of capacitance of  $2\mu\text{F}$  is first charged and then discharged through a resistance of  $2\text{M}\Omega$ . calculate the time in which the potential difference across the capacitor falls to half of its original value.

### **10 Marks**

1. Obtain the expressions for the current, impedance and phase angle in LCR Series and parallel Circuit. Under what condition will electric resonance occur?
2. Derive expressions for resonant frequency for
  - i) A series resonant circuit.
  - ii) A parallel resonant circuit.
3. Derive equation for the growth & decay of current in a circuit containing inductance resistance & a constant emf.
4. Obtain an expression for the growth & decay of charge in a condenser through a resistance.
5. Derive Helmholtz equations for the growth and decay of current in a circuit having inductance and resistance.
6. Describe, with full theory, the method of measuring a high resistance by the leakage method.



## Unit-5:ELECTROMAGNETIC THEORY

### 2 Marks

1. State Gauss divergence theorem.
2. State stoke's theorem.
3. What is meant by vector field?
4. State Green's theorem.
5. Define gradient of a scalar filed.
6. Define divergence of a vector field.
7. The divergence of a vector function is scalar. Explain.
8. Explain curl of vectors.
9. State Poynting theorem
10. What does the curl of a vector field represent?
11. Write the differential form of Ampere's law.
12. Write the integral form of Maxwell's first equation.
13. Write the differential form of Maxwell's first equation.
14. Write the integral form of Maxwell's second equation.
15. Write the differential from of Maxwell's second equation.
16. Write the integral form of Maxwell's third equation.
17. Write the differential form of Maxwell's third equation.
18. Write the integral form of Maxwell's fourth equation.
19. Write the differential form of Maxwell's fourth equation.

### 5 Marks

1. State Maxwell's equations of electromagnetic field explaining the symbols.
2. State and explain Amper's circuital law .
3. State and prove Gauss divergence theorem.
4. Derive  $\nabla \cdot E = \frac{\rho}{\epsilon_0}$ .
5. Derive  $\nabla \cdot B = 0$ .
6. Derive  $\nabla \times E = -\left(\frac{\partial B}{\partial t}\right)$ .
7. Derive  $\nabla \cdot B = \mu_0 \epsilon_0 \frac{\partial E}{\partial t}$ .
8. State and prove poynting theorem.
9. Write a note on the electromagnetic wave satisfied by E and B.
10. State and explain the energy density and intensity of electromagnetic wave.

11. Define the gradient of the scalar field. Explain it with an example to give its physical significance.
12. Define the divergence of a vector field. Give its physical significance.
13. Define the curl of a vector field. Give its physical significance.

**10 Marks**

1. State and prove poynting theorem.
2. Write a note on maxwell's equations.
3. Derive Maxwell's equation for electromagnetic waves in space.
4. Give Maxwell's equation for electromagnetic field and deduce an expression for the velocity of propagation of plane electromagnetic wave moving in a free face.
5. Write a note on the electromagnetic wave satisfied by E and B.
6. Derive the following

a.  $\nabla \times E = -\left(\frac{\partial B}{\partial t}\right)$

b.  $\nabla \times H = \frac{1}{c^2} \frac{\partial E}{\partial t}$



KLE SOCIETY'S  
**P. C. JABIN SCIENCE COLLEGE,**  
**AUTONOMOUS, CPE PHASE -III**  
AFFILIATED TO KARNATAK UNIVERSITY DHARWAD  
APPROVED BY UNIVERSITY GRANTS COMMISSION, NEW DELHI AND  
GOVERNMENT OF KARNATAKA  
**Accredited at 'A' Grade by NAAC**  
**VIDYANAGAR, HUBBALLI-580031**

---

**DEPARTMENT OF PHYSICS**

**BSc V Semester Physics Paper – I**

**Classical mechanics, Relativity & Quantum mechanics**

**2 mark questions: Classical mechanics**

1. A system of 5 particles moves in a plane. Then what will be the number of degrees of freedom?
2. Calculate the number of degrees of freedom of a system of five particles subjected to two constraints.
3. What are the numbers of degrees of freedom of a system of N particles subjected to K constraints?
4. Calculate the number of degrees of freedom for a system of 12 particles subjected to 3 constraints.
5. What is scleronomic constraint? Give an example.
6. Name the constraints which are independent of time.
7. Calculate the number of constraints, if the number of degrees of freedom for a system of 5 particles is 12.
8. What do you mean by configuration space?
9. Name the constraint which may be expressed in the form of an equation relating the co-ordinates of the system and the time.
10. What is kind of constraint of a particle restricted to move on the surface of sphere without slipping? Justify.
11. Name the constraint involved in the motion of a particle in a spherical container.
12. In which frame of reference Classical mechanics holds good.
13. Which are forms of the Lagrangian equations?.
14. What are generalised co-ordinates?

15. What are virtual displacements?
16. What are constraints?
17. State D'Alembert's principle.
18. State the principle of virtual work
19. Write an expression for a generalised force.
20. What is an inertial frame of reference?
21. Find the Lagrangian function at an instant for which the kinetic energy and potential energy of the system are 80J and 20J respectively.
22. What kind of constraint is involved in the motion of a bob of simple pendulum?
23. What kind of constraint is involved in the motion of a bob of simple pendulum with a fixed length of pendulum?
24. What kind of constraint is involved in the motion of particle in an expanding air bubble?
25. What are the consequences of two body force problem?
26. Write Lagrangian equations of motion of a body under central force.

### **Relativity**

1. State postulates of special theory of relativity.
2. What is Lorentz – Fitzgerald contraction?.
3. What is an ether medium?.
4. What is time dilation?.
5. Mention Lorentz Transformations.
6. Calculate the energy due to the conversion of 1kg mass into energy.
7. Define amu and eV.
8. Compute the apparent length of a metre rod moving with a velocity of  $c/2$  along its length.
9. How a sphere moving with a relativistic speed with respect to an observer appear?
10. What is an inertial frame of reference?
11. A body of rest mass  $m_0$  is moving with a velocity of  $(\sqrt{5} c/3)$ , where  $c$  is the velocity of light. Calculate its mass.

## Quantum mechanics

1. What is Compton effect?
2. What is the importance of Compton effect?
3. Why is Compton effect observed for X-rays and not observed for visible rays?
4. Calculate Compton shift for a photon scattered through an angle of  $90^\circ$ .
5. Why the wave nature of matter is not apparent in our daily life?
6. Which experiment confirms the wave nature of electrons.
7. An electron and proton have same de Broglie wavelength. Which one will move faster? Why?
8. Why the concept of trajectory in phase space has no meaning in quantum mechanics?
9. The period of harmonic oscillator in its ground state is 2.2 ms. Find the zero point energy.  
(Given  $h = 6.625 \times 10^{-34}$  JS)
10. Calculate change in wavelength when the recoil electron has maximum kinetic energy.  
(Given  $h = 6.625 \times 10^{-34}$  JS, electron mass =  $9.1 \times 10^{-31}$  Kg)
11. A photon recoils back after striking an electron at rest. What is the change in the wavelength of the photon?
12. A microscope using photons is employed to locate an electron in an atom to within a distance of  $0.1 \text{ \AA}$ . What is the uncertainty in the momentum of electron located in this way?
13. State Heisenberg's Uncertainty principle.
14. Write orthonormality condition of wave function.
15. State de Broglie hypothesis.
16. What are matter waves?
17. What is de Broglie wavelength of an electron of energy 100 eV?
18. What are the eigen values and eigen functions?
19. What is zero-point energy?
20. Why is it important for a wave function to be normalized?
21. Calculate the wavelength associated with 20 eV photon.
22. What is the de Broglie wavelength of an electron which has been accelerated from rest to a p.d of 100 volt?.
23. If the uncertainty in the position of an electron is  $4 \times 10^{-10}$  m, calculate uncertainty in its

momentum. Given  $h=6.625 \times 10^{-34}$  J-s

24. Give any two properties of wave functions.

### 5 mark questions:

#### Classical mechanics

1. What are constraints? Explain the different types of constraints with one example in each case.
2. State and explain the principle of virtual work.
3. Set up an equation of motion for harmonic oscillator using Lagrangian equation.
4. State and explain D'Alembert's principle.
5. Define generalised co-ordinates and obtain an expression for the generalised virtual displacement.
6. Obtain an expression for generalized velocity.
7. Obtain an expression for generalised Kinetic energy.
8. Obtain an expression for generalised force.
9. Set the Lagrangian & hence set an equation for the electrical circuit containing capacitor and inductor.
10. State and derive Kepler's second law of planetary motion.
11. State and prove Kepler's third law of planetary motion
12. Explain how a two body central force problem can be reduced to single body problem.
13. The period of earth is 365.25 days and that of venus is 224.7 days. Find the ratio of the major axes of their orbits.
14. Show that the generalized force need not always have the same dimension.
15. What are constraints? Explain holonomic and nonholonomic constraints with one example each.
16. Obtain an equation for the orbit of a particle under the action of a central force.

#### Relativity

1. Deduce Lorentz transformations by using postulates of special theory of relativity.  
Obtain an expression for length contraction.
2. Derive an expression for the relativistic length using Lorentz transformation equation.
3. Obtain an expression for length contraction.
4. Obtain the relativistic law of addition of velocities.

5. Derive an expression for the relativistic time using Lorentz transformation equation.
6. Obtain an expression for time dilation.
7. If the mass of a particle in motion is exactly thrice its rest mass, calculate the velocity of a particle. ( $c=3 \times 10^8 \text{ m/s}$ ).
8. Two spaceships X and Y are moving in opposite directions each with a speed of  $2.4 \times 10^8 \text{ ms}^{-1}$ . Find the relative speed of Y with respect to X, given the velocity of light  $= 3 \times 10^8 \text{ ms}^{-1}$ .
9. An observer on earth measures the length of a moving spaceship to be exactly  $1/4^{\text{th}}$  of its rest length. Calculate the speed of spaceship and time dilation corresponding to 2 second on spaceship.
10. An aeroplane is moving with a uniform velocity 600 mst wrt earth, By what fraction of its rest length will appear to be shortened to an observer on earth?
11. An observer an earth measures length of a moving spaceship to be exactly half its rest length. Calculate the speed of spaceship and time dilation corresponding to 1S on spaceship.
12. If the total energy of a particle is exactly thrice its rest energy, What is the velocity of a particle?
13. What is the length of a metre rod moving parallel to its length, when its mass is  $3/2$  of its rest mass?
14. How the negative result of Michelson's Morley experiment is explained by means of Lorentz-Fitzgerald contraction hypothesis?
15. The paper mean life of pion is  $2.5 \times 10^{-8}$ . What would be the mean life of a beam of a these pions travelling with a speed of a  $0.73 c$ ? Calculate the distance travelled during one mean life time.

### **Quantum mechanics**

1. Illustrate Uncertainty principle using Gamma ray microscope.
2. Describe diffraction of electrons at a single slit.
3. Write the properties of wave function.
4. Give physical significance of wave function.
5. State de Broglie hypothesis and derive an expression for de Broglie wavelength.
6. Derive an expression for the energy of a particle in one dimensional box.
7. Describe Davisson and Germer experiment to study matter waves.
8. Derive an expression for the energy of a particle in one dimensional infinitely deep potential well.
9. Discuss Compton scattering qualitatively and write the expression for Compton shift.

10. Give the physical significance of wave function and zero point energy.
11. X-rays of wavelength  $0.5\text{\AA}$  incident on few stationary electrons are scattered at  $90^\circ$ . Calculate the Compton shift and the direction of the recoil electron.
12. An electron in ground state is moving in an infinitely deep potential well of width  $20\text{\AA}$ . Find the probability of finding electron at the centre around  $2\text{\AA}$  distance.
13. The photon is confined to a nucleus of radius  $5 \times 10^{-15}\text{m}$ . Calculate the minimum uncertainty in (i) momentum; (ii) K.E. of the photon.
14. A beam of mono-energetic neutrons corresponding to  $27^\circ\text{C}$  is allowed to fall on a crystal. A first order reflection is observed at a glancing angle  $30^\circ$ . Calculate the inter planar spacing of the crystal. Given that  $h = 6.625 \times 10^{-34}\text{ JS}$ , mass of neutron  $m_n = 1.67 \times 10^{-27}\text{ Kg}$  and Boltzmann constant  $k = 1.38 \times 10^{-23}\text{ J/K}$ .
15. An electron is bound by a potential which closely approaches in infinite square well of width  $2.5 \times 10^{-10}\text{m}$ . Calculate the lowest three permissible quantum energies the electron can have.
16. The energy of a linear harmonic oscillator in its third excited state is  $0.1\text{eV}$ . Calculate its frequency.
17. In Davison and Germer experiment, electrons are accelerated to a pd of  $55\text{V}$  and get reflected at  $50^\circ$  in the 1<sup>st</sup> order. Calculate the wavelength of these electrons. What would be the pd if electrons are reflected at  $48^\circ$  in the second order (Given  $d = 2.2\text{\AA}$ )
18. X-rays of wavelength  $0.5\text{\AA}$  are incident on free stationary electrons and get scattered directly backwards. Calculate the wavelength of scattered X-rays.

### 10mark questions:

#### Classical mechanics

1. What are generalized coordinates? Obtain an expression for generalized potential.
2. State Kepler's laws of planetary motion. Deduce Kepler's third law of planetary motion.
3. Using D'Alembert's principle derive Lagrangian equation of motion.
4. State and explain the principle of virtual work. Hence arrive at D'Alembert's principle.
5. Set up the Lagrangian equation for a particle moving in central force field. Show that the total energy of a particle moving in a central force field remains constant.
6. Reduce two-body central force problem to an equivalent one body problem and hence derive an expression for total energy of the system.
7. Obtain the expressions for a) Generalised Kinetic energy b) Generalised Potential energy.



8. State Kepler's laws of planetary motion. Deduce Kepler's first law using Lagrangian equation.
9. Setup Lagrangian equation for :
  - a) Linear harmonic oscillator
  - b) Electrical circuit consisting of an inductor and a capacitor.
10. State Kepler's laws of planetary motion. Derive Kepler's second law of planetary motion.
11. Obtain equations of motion of a body under the action of a central force.
12. Deduce an expression of the reduced mass of two body force problem & Hence explain the following
  - a) Revolution of planets around sun
  - b) Falling of a stone on earth.
13. Deduce an expression for the orbit of a particle under the action of a central force & hence explain different types of orbits.

### **Relativity**

1. Explain with relevant theory, Michelson Morley experiment.
2. Deduce an expression for the relativistic mass & show that rest mass is least.
3. Obtain an equation for the orbit of a particle under the action of a central force & Explain different types of orbits.
4. State & Prove Einstein's mass-energy equivalence. Give examples
5. Obtain the relativistic law of addition of velocities. Show that no object can travel with a velocity greater than that of light.
6. Derive Einstein's mass-energy relation. What is its physical significance?.

### **Quantum mechanics**

1. State and explain uncertainty principle. Illustrate the principle with Gamma ray microscope.
2. Derive an expression for energy of a particle in one dimensional box.
3. Deduce the time independent Schrödinger's wave equation
4. Write Schrödinger's time independent wave equation for a particle. Explain the physical significance of wave function, eigen function and eigen values. What is the concept of zero point energy?
5. Write Schrödinger's wave equation for a linear harmonic oscillator and hence show that its energy is quantized. Explain the concept of zero point energy.
6. Write Schrödinger's wave equation for a linear harmonic oscillator. Write the expression for its energy levels. Show that its energy is quantized.

7. What is Compton effect ? Derive an expression for Compton Shift.
- 8 a. Write a note on eigen functions and eigen values.
  - b. Discuss the permitted energy levels of a linear harmonic oscillator.
9. Develop the time independent Schrödinger's wave equation. What are the conditions that must be satisfied by the solution of the above wave equation.



**DEPARTMENT OF PHYSICS**

**B.Sc V Semester Paper –II Question Bank**

**Unit I : Electronics and communication**

**Two Marks Questions**

1. State superposition theorem.
2. State Thevenin's theorem.
3. State Norton's theorem.
4. State Maximum power transfer theorem..
5. When is the maximum power delivered? Write an Expression for maximum power.
6. What is meant by voltage source?
7. What is meant by current source?
8. Draw the symbol of ideal voltage ac source .
9. Draw the symbol of ideal current ac source .
10. Draw the symbol of ideal current dc source .
11. Name the devices whose characteristics are close to that of an ideal current and voltage source.
12. Draw the symbol of ideal voltage dc source.
13. Using Thevenin's theorem, find the voltage across AB in the circuit given below.

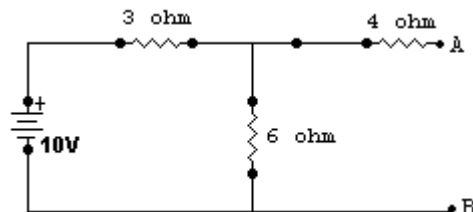

14. Find the Norton's current for the following circuit

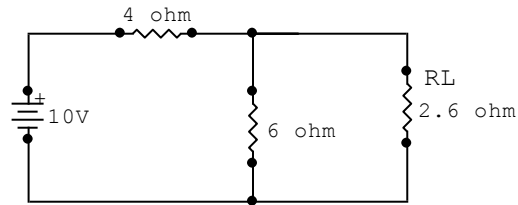

15. Using Milliman's theorem, find the voltage across XY terminals in the circuit given below.

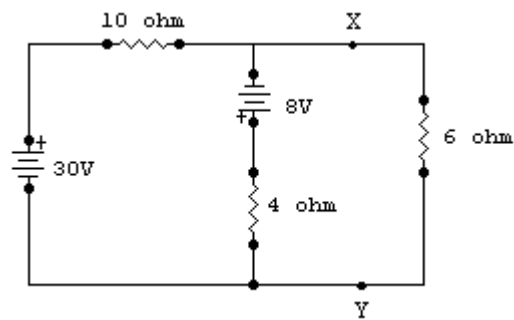

1. A constant source applied a current of 300 mA to a load of 1K ohm when the load is changed to 100 ohm, What will be the load current
2. Draw the Norton's equivalent circuit
3. Draw the Thevenin's equivalent circuit
4. What is power supply?
5. Mention the constituents of the power supply
6. Draw the circuit diagram IC based regulated power.
7. Define rectification.
8. What is rectifier?
9. Define efficiency of a rectifier.
10. Define ripple factor of a rectifier.

11. What do you mean by regulation?
12. What is PIV?
13. In bridge rectifier input is from 230V, 50Hz what is the D.C. output voltage & peak Voltage
14. Sketch the input & output waveforms in case of half wave rectifier.
15. Sketch the input & output waveforms in case of full wave rectifier.
16. Sketch the input & output waveforms in case of bridge rectifier.
17. Draw the circuit diagram of. half wave rectifier
18. Draw the circuit diagram of. full wave rectifier.
19. Draw the circuit diagram of. bridge rectifier
20. Give advantage of half wave rectifier
21. Give advantage of full wave rectifier.
22. Give advantage of bridge rectifier
23. Give demerits of half wave rectifier
24. Draw the circuit diagram IC based regulated power supply
25. what are the advantages of IC regulator over Zener as a voltage regulator
26. why Zener diode is called voltage reference source.
27. what is Zener diode draw the symbol?
28. Draw the equivalent circuit of Zener diode
29. what is voltage regulation?
30. write the expression for percentage voltage regulation
31. Which characteristic of a diode is responsible for the rectification?
32. Name the active component used for rectification
33. What is power supply? Mention the constituents of power supply
34. Define rectification
35. Show that maximum rectification efficiency of a half wave is 40.6%
36. Show that maximum rectification efficiency of a full wave is 81%
37. Explain why we need filters in power supply
38. when do we prefer inductor, filter?

39. Why is capacitor input filter preferred over choke input filter
40. How is the ripple reduced to using a capacitor filter
41. How is the ripple reduced to using an inductor filter
42. How is the ripple reduced to using an LC filter
43. What is a transistor?
44. What is a Transistor? Mention the types with symbols representation.
45. Write the current equation and explain the terms.
46. Sketch the typical input & output characteristics of a polar transistor. When connected in CE configuration.
47. Obtain the relation between  $\alpha$  and  $\beta$  of a transistor.
48. Explain why CE configuration is most popular in amplifier circuit?
49. What are the hybrid parameters
50. A transistor has  $\beta=150$ , Calculate the approximate collector & base current, if the emitter current  $I_E=12\text{mA}$
51. If for the transistor  $\alpha=0.95$  &  $I_E=1\text{mA}$ . Find the values of  $I_C$  &  $I_B$
52. Name the different configurations for the transistor.
53. In CE connected transistor has  $\beta=100$ ,  $I_B=50\mu\text{A}$ . Compute the values  $\alpha$ ,  $I_C$  &  $I_E$
54. Name the h-parameter for transistor in CE mode.
55. Define input impedance of a transistor in CE mode.
56. Define output admittance of a transistor in CE mode
57. Define reverse Current gain of a transistor in CE mode
58. Define forward voltage gain of a transistor in CE mode
59. Define Draw the circuit diagram of emitter follower.
60. Why common collector configuration is called emitter follower?
61. What is a field effect transistor?
62. Name the parameter of FET.
63. Write the expression for Drain resistance in case of FET.
64. Write the expression for Transconductance in case of FET.

65. Write the expression for amplification factor in case of FET
66. Draw the symbol of NPN & PNP transistor & specify the leads
67. Name the 3 possible transistor configuration
68. Why is collector wider than emitter & base?
69. Why is collector is less than emitter current?
70. Why is base made thin?
71. What is faithful amplification?
72. What do you understand by transistor?
73. Find the value of  $\beta$  if 1.  $\alpha=0.9$  , 2.  $\alpha=0.98$
74. Calculate emitter current in a transistor for which  $\beta=50$  &  $I_b=20\mu A$
75. Sketch the small signal h-parameter equivalent circuit of a transistor amplifier in CE mode.
76. Explain the function of the coupling capacitor in common emitter amplifier circuit
77. Explain the function of bypass capacitor in common emitter amplifier circuit.
78. Why common collector amplifier is called as emitter follower?
79. Write the special features of CE amplifier.
80. Write the special features of CC amplifier.
81. Define current gain or current amplification  $A_i$  of an amplifier.
82. Define voltage gain of an amplifier.
83. Define power gain of an amplifier.
84. What is meant by an frequency response of an amplifier circuit?
85. Draw frequency response curve for CE amplifier transistor and mark upper and lower half power frequency.
86. The CE amplifier is supposed to be a best amplifier among the three configurations. Give reason
87. Define bandwidth.
88. What is FET?

89. Why FET is called a unipolar transistor?
90. Mention types of FETs.
91. Why is the input impedance of a FET higher than of an ordinary transistor?
92. Why does a FET have low noise level?
93. Why is the input impedance of a MOSFET higher than that of a FET?
94. Why is MOSFET useful in frequency applications?
95. In a FET a change in gate voltage of 0.1V causes a change of 0.3mA is drain current. What is the transconductance?
96. A FET has an amplification factor of 50. What does it mean?
97. A FET has an amplification factor is 10k ohm and transconductance of 3000 $\mu$ mhos. What is its amplification factor?
98. In FET a change in drain voltage of 2V produces a change in drain current of 0.02ma. What is the ac drain resistance?
99. When the gate to source voltage (VGS) of a FET changes from -3.1V to -3V the drain current (ID) changes from 1mA to 1.3mA. What is the value of transconductance.
100. What is a Feedback?
101. Mention the type of feedback.
102. Define negative feedback.
103. Define the positive feedback.
104. Mention the disadvantage of positive feedback in amplifier with a negative feedback
105. Write down the equation of voltage gain of amplifier with a negative feedback.
106. What will be the effect of negative feedback on the gain of an amplifier.
107. What will be the effect of negative feedback on input impedance amplifier.
108. What will be the effect of negative feedback on output impedance amplifier?
109. Which type of feedback is used in oscillator?



110. When does a transistor amplifier acts as an oscillator?
111. Write down the condition for sustained oscillation.
112. What is the Barkhausen criterion for sustained in oscillation.
113. What is function of feedback network in basic network.
114. What are the fundamental assumptions made for feedback amplifier.
115. Mention the general properties of negative feedback.
116. Give the advantages of negative feedback.
117. What type of feedback is used in emitter follower circuit?
118. Write the expression of frequency for sustained oscillation in case Hartely oscillator.
119. Write the expression of frequency for sustained oscillation in case Wien Bridge oscillator.
120. Mention advantages and disadvantages of Wein bridge oscillator.
121. The Hartley oscillator has frequency of 4000KHz the capacitance 100pF. Find the self-inductance of the coil neglecting the mutual inductance between the two portions of the coil.

## **Unit II Digital Electronics**

122. What are logic gates?
123. Mention special features of Boolean algebra
124. What is truth table?
125. What do you mean by universal gates?
126. Why NAND and NOR gates are called universal gates?
127. Draw the logic symbol of basic gates.
128. Draw neat circuit diagram of a two input diode AND gate.
129. Draw neat circuit diagram of a two input diode OR gate.
130. Draw neat circuit diagram of a two input diode NOT gate.
131. Draw neat circuit diagram of transistor as an inverter.

132. Write the truth table for three input OR gate.
133. Write the truth table for three input AND gate.
134. Mention the importance algebraic properties of XOR gate.
135. Why XOR gate is called or odd number 1's detector?
136. Why XNOR gate is called or even number 1's detector?
137. Implement XOR gate using basic gates.
138. What is timing diagram?
139. What do you mean by positive logic?
140. What do you mean by negative logic?
141. Implement  $Y = A + B C$  using basic gate.
142. Prepare truth table for  $Y = A + B C$
143. State De-Morgan's theorem.
144. What Boolean algebra?
145. Two electric signals represented by 101101001 and 111001101 are applied to OR gate. Draw the output timing diagram.
146. Implement  $Y = A B + C D$  by using NAND gates only
147. Find the decimal equivalent of a)  $[4A]_{16}$  b)  $[10110]_2$
148. Find binary equivalent of a)  $[29]_{10}$  b)  $[0.62]_{10}$
149. Find the hexa-decimal equivalent of a)  $[93]_{10}$  b)  $[110110.0110101]_2$
150. What is the decimal equivalent of  $[25]_8$
151. What is the decimal equivalent of  $[AB]_{16}$
152. What is the binary equivalent of  $[DAD]_{16}$
153. Name the different number systems
154. What is binary number system?
155. What is octal number system?
156. What is Hexa number system?
157. How many basic digit are present in the hexa decimal number system? write them.
158. What is the most significant digit in a number system?

159. What is the least significant digit in a number system?

### **Unit –III Modulation**

160. what is ionosphere ? Mention its different layers .

161. What is virtual height?

162. What is critical frequency?

163. What is maximum usable frequency?

164. What is skip distance?

165. State secant law.

166. What is modulation? Why is it needed?

167. What is Amplitude modulation?

168. What is frequency modulation?

169. What is Phase modulation?

170. For an amplitude modulated carrier waves, the maximum & minimum amplitudes are 600 mv & 200 mv respectively, calculate the modulation index.

171. The carrier power radiated from the transmitter is 50 KW & fully modulated. What is the power in the side band?

172. A 100 KHz carrier is amplitude modulated with 1500 Hz audio signal. What are the upper & lower side band frequencies?

173. A sinusoidal carrier voltage of frequency 10 MHz & amplitude 200 V is amplitude modulated by sinusoidal voltage of 10 KHz producing 40% modulation. Calculate the band width & amplitude of each side band.

174. What is modulation? What are the types of modulation?

175. What is side band? What are the types of sidebands?

176. What is Band width? Write the expression for band width.

177. What is modulation index in AM Wave?

178. What are the main functions of IF amplifier in super heterodyne receiver?

179. What is super heterodyne receiver?
180. Give the principle of super heterodyne receiver.
181. Name the different blocks of super heterodyne receiver.
182. Explain the working of mixer in super heterodyne receiver?
183. What are the drawbacks of AM technique?
184. What is efficiency of transmission in AM Wave?
185. What is frequency modulation?
186. What is frequency deviation? When does the frequency deviation become Maximum?
187. What is modulation index in frequency modulation.
188. What are the advantages of FM over AM?
189. What is phase modulation?
190. What is Linear detector?
191. What is Square law detector?
192. What is Demodulation?
193. Explain the square law detection.
194. What is demodulation? Why is it required?
195. Draw the Circuit diagram of AM diode detector.
196. A 100 KHz carrier is amplitude modulated with 1000 Hz audio signal. What are the upper and lower side band frequencies?
197. Write the expression for a) The instantaneous voltage of AM Wave b) The relation between total power and carrier power of an AM Wave.
198. Draw the circuit diagram of AM diode detector
199. What is the importance of side bands in AM technique?
200. Draw the frequency response curve of balanced slope detector.
201. The maximum frequency deviation of an FM signal is 10 KHz. The maximum modulating frequency is 3.33KHz. Find deviation ratio.
202. The total AM signal power is 2800 W the carrier power is 2000W. Find the modulation index.

203. Give any two flow chart symbols.
204. What is computer?
205. Define programme in C- language.
206. What are flow charts? Give their symbols.
207. What is data?
208. Variable means what?
209. Name the types of variables.
210. Give the Essential features of program.
211. What is the importance of header files?
212. Name the basic input/output statement functions.
213. When void main () is used in C Programming ?
214. What is source file ?
215. Write any two features of C language
216. List the various compilers available in C
217. What is necessity of an Operating System for C program ?
218. What are special characters in C ? Give any two.
219. List out the four basic data types in C.
220. List the four basic types of constants in C.
221. Identifiers and keywords means what?
222. Give the structure of a simple C Program.
223. Give the syntax of increment and decrement operators in C.
224. Give the syntax of IF – ELSE statement in C.
225. What is algorithm? Is it essential to write programme?
  
226. List the logical operators in C .Write their meanings.
227. How do you separate set of expressions of a C program ?Write an example.
228. Give the difference between while – do and do-while loop.
229. Write the declaration statements for the following  
Integer variables : X ,Y, Z

Floating point variable:p,q

### 5 mark questions

1. State and explain Thevenin's theorem.
2. State and explain Norton's theorem.
3. State and explain superposition theorem.
4. State and explain Maximum power transfer theorem.
5. Using Norton's theorem, calculate the current following through  $12\Omega$  resistor shown in fig. Given below

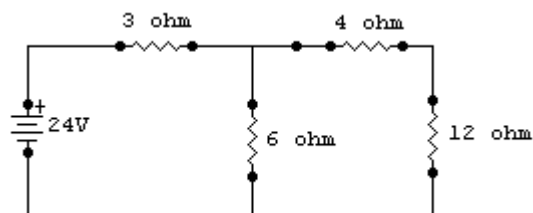

6. In the circuit given below compute the value of load resistance for maximum power transfer theorem and also calculate max power delivered.

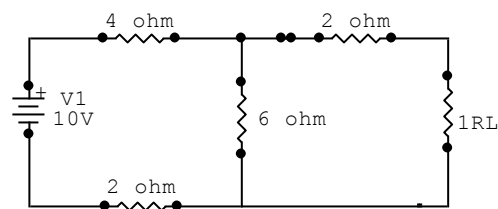

7. Calculate current in each branch of the network shown below and verify using superposition theorem

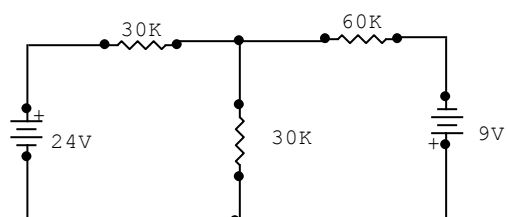

8. In a circuit given below calculate the current through resistance  $R_3$  using superposition theorem

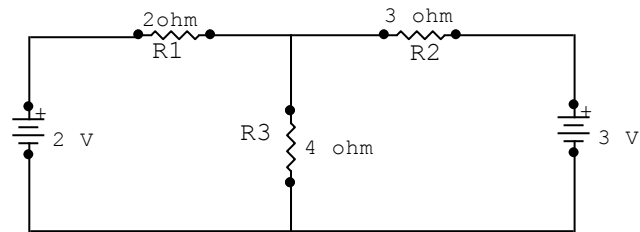

1. Explain the action of diode as a half wave rectifier.
9. Explain the action of diode as a full wave rectifier
10. Explain the action of diode as a Bridge wave rectifier
11. Derive an expression for efficiency of half wave rectifier.
12. Derive an expression for efficiency of half wave rectifier
13. Derive an expression for efficiency of full wave Bridge rectifier.
14. Obtain a ripple factor of a half wave rectifier.
15. Give Comparison between, half wave and full wave and full wave Bridge rectifier.
16. Explain zener breakdown and avalanche break down.
17. Draw and explain characteristics of zener diode
18. Explain the working of capacitor filter.
19. Explain the choke input filter with neat diagram.
20. Describe the working of capacitor input filter or  $\pi$ - filter.
21. What are like L- section filter? Explain the working of it.
22. Explain the working of shunt capacitor filter with neat circuit diagram.
23. Why we need filter in power supply? What or meant by regulation of a power supply?
24. Explain with circuit diagram the working LC choke input filter.  $\pi$ -section filter and explain the \_\_\_ of bleeder resistor in the choke input filter.

25. In a center tap full wave rectifier the load resistance  $R_L=3k\Omega$  voltage across the half the secondary winding or  $230 \sin 314 t$ .
- Find i. Peak value of the current. ii. The dc or avg value of current.
- iii. rms or avg value of current. Iv. Ripple factor and the rectification efficiency.
26. What are hybrid parameter? Define  $h_{ie}$ ,  $h_{oe}$   $h_{fe}$  &  $h_{re}$  of a transistor in CE-configuration.
27. With neat circuit diagram explain the working of emitter follower.
28. With neat circuit diagram explain the working Hartley oscillator. Write expression for frequency relation.
29. With neat circuit diagram explain the working Wein Bridge. Oscillator and write expression for frequency relation.
30. Find the frequency of Astable. Multivibrator based on IC-555 Timer with  $(R_1 = \text{Twice the } R_2) = R_1=2R_2$  Where  $R_1=3.9k\Omega$   $C=530 \text{ nf}$ .
31. With neat circuit diagram describe the working of a single stage RC coupled amplifier.
32. An amplifier when loaded with by  $2k\Omega$  resistor has a voltage gain of 80 and a current gain of 120. Determine the necessary signal voltage and current to give an output voltage of 1V. What is the power gain of the amplifier?
33. In a transistor amplifier if  $R_c=10k\Omega$   $R_L=10k\Omega$   $R_{in}=2.5k\Omega$   $\beta=100$ . Find the output voltage for an Input voltage of 1mV r.m.s
34. In the circuit diagram in fig below. Find the voltage gain given  $\beta=60$  &  $R_{in}=1k\Omega$ .

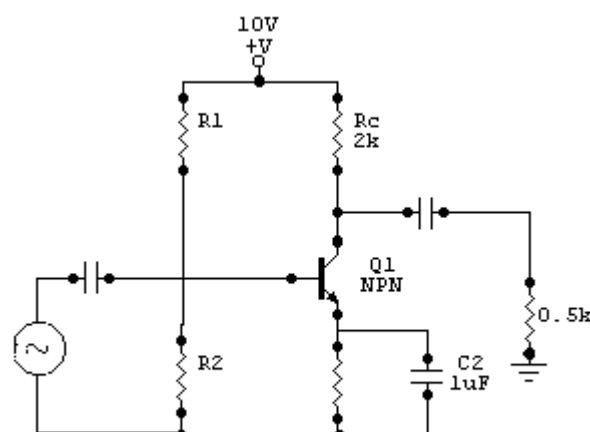



35. In the transistor amplifier find the output voltage if I/P resistance is  $R_{in} = 0.5\text{ kohm}$ ,  $\beta = 50$ ,  $V_{in} = 1\text{ mV}$ ,  $R_1 = 10\text{ kohm}$ ,  $R_2 = 3\text{ kohm}$ ,  $R_E = 3\text{ kohm}$ ,  $R_L = 6\text{ kohm}$ ,  $R_C = 2\text{ Kohm}$ .
36. Draw the freq response of an CE amplifier and state reasons for its shape at mid – band frequency ,low frequency and high frequency region.
37. Draw the freq response of an CE amplifier and state reasons for its shape at mid – band frequency ,low frequency and high frequency region.
- Explain the construction of FET.
38. Explain the working of FET.
39. What is the difference between FET and a bipolar transistor?
40. How do you determine drain characteristics of FET?
41. Define the FET parameters and establish relation between them.
42. Describe practical applications of FET.
43. Explain the construction of MOSFET.
44. Explain the working of MOSFET.
45. The RC network of the Wein bridge oscillator consists of capacitors and resistors of values  $C_1 = C_2 = 250\mu\text{F}$  and  $R_1 = R_2 = 220\Omega$ . Determine frequency of oscillation.
46. Explain the general theory of feedback (or principle of feedback).
47. Sketch the four basic feedback connections and explain them.
48. List the properties of negative feedback.
49. List the advantages of negative feedback.
50. Derive an expression for input impedance of a feedback amplifier.
51. Prove that output impedance reduces due to negative feedback.
52. Show that negative feedback in amplifier decreases lower cutoff frequency.
53. Show that negative feedback in amplifier increases upper cutoff frequency.
54. Show that negative feedback in amplifier increase bandwidth.

55. Explain Barkhausen's criterion for sustained oscillation.
56. The overall gain of an amplifier is 140. When negative feedback is applied, the gain is reduced to 17.5. Find the fraction of output that is feedback to the input.
57. When negative feedback is applied to an amplifier of gain 100, the overall gain falls to 50. Calculate
58. The fraction of output feedback.
59. If this fraction is maintained, calculate the value of the amplifier gain required if the overall stage gain is to be 75.
60. With a negative feedback amplifier gives an output of 10V with an input of 0.5V. When feedback is removed it requires 0.25V input for the same output. Calculate (i) Gain without feedback (ii)  $\beta$ .
61. An amplifier with negative feedback has voltage gain 100. It is found that without feedback an input 50mA is required to produce a given output, whereas with feedback, input signal must be 0.6V for the same output. Calculate the  $A_v$  and  $\beta$ .
62. An amplifier has bandwidth 20KHz and voltage gain 40. Compute the bandwidth and gain if a negative feedback of 1% is given to this amplifier.
63. An amplifier has bandwidth 20KHz and voltage gain 40. Calculate the bandwidth and voltage gain after a negative of 2% is supplied to this amplifier.
64. State & prove Thevenin's theorem
65. State & prove Norton's theorem
66. State & prove Superposition theorem
67. State & prove Maximum power transfer theorem
68. Write a note on Number system
69. Explain the procedure to convert decimal integer to any other base with example

70. Explain the procedure to convert binary integer to any other base with example
71. Explain the procedure to convert binary fraction to any other base with example
72. Explain the procedure to convert hexa decimal fraction to any other base with example
73. Discuss the laws of Boolean algebra
74. State & explain the concept of duality principle with example
75. What is Boolean algebra? Discuss 3 boolean operators
76. What is AND gate? Explain the concept of AND gate using switching circuit
77. With neat circuit diagram explain the working of 2 input diode AND gate
78. What is OR gate? Explain the concept of OR gate using Switching circuit, draw truth table & graphic symbol
79. With neat circuit diagram explain the working of 2 input diode OR gate
80. What is NOT gate? Explain the concept of NOT gate using Switching Circuit draw the truth table & graphic symbol
81. What is NAND gate? Explain the concept of NAND gate using Switching Circuit draw the truth table & graphic symbol
82. What is NOR gate? Explain the concept of NOR gate using Switching Circuit draw the truth table & graphic symbol
83. Write a note on XOR gate
84. Write a note on XNOR gate
85. Why NAND gate is called universal gate? Justify with 2 examples
86. Why NOR gate is called universal gate? Justify with 2 examples
87. State & prove any one De Morgan's theorem. Explain circuit implications
88. With neat circuit diagram explain the principle of RTL NOR gate
89. With neat circuit diagram explain the principle of DTL NAND gate
90. With neat circuit diagram explain the principle of TTL NAND gate

91. Draw neat functional diagram of 555 Timer as astable multi vibrator & explain its working
92. Draw neat functional diagram of 555 Timer as monostable multi vibrator & explain its working
93. Discuss the construction & working of half adder.
94. Discuss the construction & working of full adder.
95. Obtain the expression for amplitude modulated wave. And the expression for original carrier wave, upper side and lower side frequencies.
96. What are the differences between AM & FM?
97. The r. m. s. value of carrier voltage is 100 V after amplitude modulation by a sinusoidal voltage. The r. m. s. value becomes 110 v. Calculate the modulation index. If modulations index is 0.5, what fraction of total power is carried by side-bands.
98. Explain frequency modulation. What are its advantages over AM?
99. Explain amplitude modulation frequency spectrum..
100. A frequency-modulated wave is represented by the equation.
  - a.  $e = 10 \sin ( 8 \times 10^8 t + 4 \sin 1200 t )$
  - b. Calculate i) Carrier frequency ii) Modulating frequency iii) Modulation index ; & iv) Maximum deviation
101. Write a note on frequency modulated transmitter.
102. A Carrier of frequency 3 MHz & amplitude 110 Volts is amplitude modulated by a signal of frequency 12 KHz producing 60% modulation. Calculate the frequency & the amplitude of the upper & the lower side bands.
103. A Carrier of frequency 12 MHz & amplitude 120 Volts is amplitude modulated by a signal of strength 10 KHz. if the amplitude of each side band is 25 Volts, find the i) modulation index. ii) The frequency of USB & iii) frequency of LSB.

104. The carrier power radiated from the transmitter is 75 KW. If the percentage of modulation is 48, calculate the total power.
105. What are frequency modulation & the phase modulation?
106. The load current in the transmitting antenna of an unmodulated AM transmitter is A. What will be the antenna current when the modulation is 35%.
107. What is the Power developed by an amplitude modulated wave in a load of  $60 \Omega$  when the peak voltage of the carrier is 100 V & the modulation index is 0.5
108. A Carrier Wave of power 400 watts is amplitude modulated to a depth of 100%. Find the power of the modulated wave & also in side bands.
109. The load current in the transmitting antenna of an unmodulated AM transmitter is 8A what will be the antenna current when the modulation is 40%.
110. An amplitude-modulated carrier wave has the maximum & the minimum amplitude is 170 mv & 250 mv respectively. Calculate the modulation index & the percentage modulation.
111. A FM wave represented by the voltage equation  $V = 16 \sin ( 4 \times 10^7 t + 6 \sin 200 t )$  Find the carrier & modulating frequencies, the modulation index & the maximum frequency deviation in the FM. What power will this FM voltage dissipate in a  $12\Omega$  resistor.
112. A Carrier voltage of frequency 2 MHz & amplitude 100 Volts is amplitude modulated by a signal frequency 10 KHz, producing a 50% modulation. Calculate the frequency & amplitude of the upper and lower side bands. To get the amplitude of 40 V for the LSB. What is the required modulation index.
113. Find the Carrier frequency modulating frequency. Modulating index and maximum frequency deviation of FM wave given by the expression

$$i. V = 12 \cos [ 6 \times 10^8 t + 5 \sin 1250 t ]$$

114. Explain the working of transistor as AM detector with Circuit diagram.
115. A Carrier voltage of frequency 1 MHz & amplitude 50 Volts is amplitude modulated by a signal frequency 5 KHz, producing a 50% modulation. Calculate frequency and amplitude of the upper and lower side band.
116. Define Amplitude modulation. Derive an expression for instantaneous amplitude of AM wave.
117. Define modulation index. Derive an expression for modulation index in terms of peak amplitudes of carrier modulating signal.
118. Discuss and compare the merits and demerits of Amplitude modulation technique with that of frequency modulation technique.
119. Define frequency modulation and derive an expression for modulation index. Define deviation ratio.
120. Define phase modulation. Derive an expression for instantaneous voltage of P.M
121. Distinguish between machine language and high level language.
122. With necessary block diagram describe the functions of Input and output units and CPU of a computer system.
123. Write the symbols of Flow charts, draw the flow chart to find the largest among three numbers.
124. When do you prefer if-else statement? Differentiate it with for loop statement with suitable flowchart.
125. Give the syntax and Flow chart for if and if-else statement in C language.
126. Write the important characteristics of C language .
127. Write the Basic Structure of C program explain each part .
128. Explain the difference between while and do-while loops with respect to the minimum number of times the body is executed.
129. Write a C Program to compute the roots of a quadratic equation
130. Write a C Program to show the year given is leap year.

**Ten Marks Questions.**

1. State and prove maximum power transfer theorem Obtain the expression for maximum power and explain load matching
2. State and prove superposition theorem
3. a) State and explain Norton's theorem.  
 b) In circuit diagram given below find load current load voltage using Norton's theorem and also draw Norton's circuit

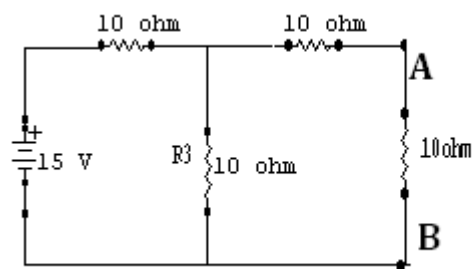

4. State and prove Thevenin's theorem. Draw equivalent circuit
5. How can be a star network converted into a delta network and delta network into a star network?
6. a) State and explain superposition theorem.  
 b) Calculate current through each branch and verify using superposition theorem.
7. a) State and explain Maximum power transfer theorem.  
 b). In the circuit shown below find value of load resistance  $R_L$  and maximum power delivered.

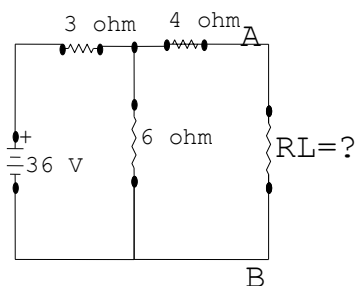

9. Describe construction and working of half wave rectifier and obtain expression for
  - a) Average dc current
  - b) rms value of current
  - c) efficiency of the circuit.
10. Discuss the construction and working of half wave rectifier Derive an expression for efficiency and ripple factor.
11. Describe construction and working of full wave rectifier and obtain an expression for
  - a) Average dc current
  - b) rms value of the current
  - c) efficiency
12. Describe construction and working of bridge rectifier and obtain an expression for
  - a) Average dc current
  - b) rms value of the current
  - c) efficiency
13.
  - a) . why we need filter in a power supply?
  - b) explain the term percentage voltage regulation.
  - c) explain with neat circuit diagram working of LC section filter.
14.
  - a) . why we need filter in a power supply?
  - b) explain the term percentage voltage regulation.
  - c) explain with neat circuit diagram working of  $\pi$  section filter.
15.
  - a) what is a zener diode
  - b) with neat circuit diagram explain the characteristic of zener diode.
  - c) explain the use of zener diode as a voltage regulator.
16.
  - a) Draw the circuit of a practical single stage transistor amplifier. Explain the function of each component.
  - b) What do you understand by ac and dc load lines? How would you construct them on the output characteristics?
17. Obtain expressions
  - 1) input impedance
  - 2) out put impedance
  - 3) current gain
  - 4) voltage gain
  - 5) power gain using hybrid equivalent circuit of single stage CE transistor amplifier
18. Using circuit diagram explain the working of a single stage RC coupled CE amplifier. Discuss the frequency response curve.
19. .a) What are hybrid parameters?



- b) Describe an experiment to hybrid parameters of transistor in CE mode.
20. a) What is feedback in amplifier.
- b) Distinguish between positive feedback and negative feedback
- c) Explain the working of emitter follower as an example of negative feedback.
21. Explain the working of Hartley oscillator with necessary circuit. Find the condition for sustained oscillation.
22. (a) State and Explain Barkhausen criterion for sustained oscillations.
- (b) Explain the working of phase shift oscillator with a circuit diagram.
23. Explain the phase shift oscillator with necessary circuit. Hence derive an expression for the frequency of oscillation. Obtain the condition for sustained oscillations.
24. (a) Sketch the four basic connections of feedback using block diagrams.
25. (b) Explain the working of tuned collector oscillator with circuit diagram.
26. Explain the construction and working of tuned collector oscillator. Hence calculate the frequency of oscillations. Mention the advantages.
27. a) What is an oscillator? Mention the different types of Oscillator.
28. b) Explain the working of Wein-bridge oscillator
29. Explain the working of Wein-bridge oscillator. Hence find frequency of oscillation. Obtain the condition for sustained oscillations
30. a) What is an oscillator? Mention the different types of Oscillator.
- b) Explain the working of Hartley oscillator
31. Explain the construction and working of FET.
32. What is FET?.mention different types of FET.
- b) Describe an experiment to determine different parameters of FET.
- c) Define drain resistance, transconductance and amplification factor.
33. What is the difference between FET and a bipolar transistor?
34. Explain the construction and working of MOSFET.
35. How do you determine drain characteristics of FET?

36. Describe practical applications of FET.
38. a. What is an oscillator ? Mention different types of oscillator based on \_\_\_\_  
b. Explain Barkhausen criterion for sustained oscillator
39. With neat circuit diagram explain the working Wein Bridge oscillator.  
With neat circuit diagram explain the working Hartely oscillator.
- a. What is feedback in amplifier? .  
b. Write the distinguish between the negative feedback. And positive feedback.  
c. Explain the working of emitter follower as an example of negative feedback.
40. a. With neat circuit diagram FET as an amplifier in common source mode..  
b. Explain the working of MOS FET
41. a. What is FET?. Mention different types FET.  
b. Describe an experiment to determine different parameters of FET.  
c. Define drain resistance, trans conductance & amplification factor of FET
42. With neat circuit diagram, Describe the operation of IC based astable multivibrator.
43. With neat circuit diagram, Describe the operation of IC based bistable multivibrator.
44. With neat circuit diagram, Describe the operation of IC based monostable multivibrator.
45. a. Explain the steps involved converting decimal integer to binary integer and vice versa with two examples.  
b. Explain the steps involved converting Hexdecimal fraction to binary fraction and vice versa with two examples.
46. What adder? With neat circuit diagram, Explain of half adder and give its truth table.
47. What adder? With neat circuit diagram, Explain of full adder and give its truth table.
48. What a logic family? Mention the different logic families.

49. Explain the working of RTL NOR gate.
50. What a logic family? Mention the different logic families.
51. Explain the working of DTL NOR gate.
52. What a logic family? Mention the different logic families.
53. Explain the working of TTL NOR gate.
54. Draw the logic symbol and truth table for each of the following gates.
  - a. Three Input OR gate
  - b. Two Input NAND gate
  - c. Three Input XOR gate.
55. State and prove a. Commutative and Associative property of Boolean algebra
56. Distributive property of Boolean algebra
57. Write a note on Programming languages
58. What are the preliminaries of a programming ? Give an example in C .
59. Explain the role of the initialization, test and update expressions in a for loop .
60. Write a program to accept a string and an integer, and Print the string as many times the integer value.
61. Write a C Program using if else statement to compute the gain of an Inverting and Non-Inverting amplifier using op-amp.
62. A) Explain different types of operator and expressions.
  - b) Give the syntax of IF-ELSE and for loop statement.
63. a) Derive an expression of instantaneous Voltage of AM Wave. b) Obtain the relationship between the total power and carrier power of an AM Wave.
64. a) Derive an Expression for instantaneous voltage of an FM Wave.
  - b) Obtain the relationship between total power and carrier power of an AM wave.
1. a) Obtain an expression for amplitude-modulated wave.
  - b) With a neat circuit diagram, explain the working of balanced slope detector.
66. a) Explain the terms "Modulation and De modulation"? Why are they required?
  - b) Explain amplitude modulation and frequency modulation with suitable waveforms.
67. Distinguish between AM & FM. Obtain an expression for the instantaneous Voltage of an amplitude modulated wave

68. Obtain an expression for the instantaneous voltage of i) an amplitude modulated wave ii) an frequency modulated wave.
- Derive an expression for the amplitude-modulated voltage.
  - Draw the circuit of square law diode detector and explain the function of each block.
69. Obtain an expression for the instantaneous voltage of an AM Wave in terms of side bands. Explain output spectrum.
70. Explain the construction and working of square law diode detector.
71. a) .What do you mean by superheterodying?
- Draw the block diagram of superheterodyne receiver and explain the each block.
72. a. Explain the steps involved in a decimal interger to binary integer and vice-versa with two example
- Explain the steps involved in a hexadecimal fraction to binary fraction and vice-versa with two example
73. What is an oscillator ? Mention different types of oscillators.
- Explain Barkhausen criterion for sustained oscillator.
74. With neat circuit diagram explain the working\_Wein Bridge oscillator.
75. With neat circuit diagram explain the working Hartely oscillator.
76. a. What is feedback in amplifier .
- Distinguish between the negative feedback and positive feedback.
  - Explain the working of emitter follower as an example of negative feedback.\_
77. With neat circuit diagram FET as an amplifier in common source mode..
- Explain the working of MOS FET
- 78a. What is FET?. Mention different types FET.
- Describe an experiment to determine different parameters of FET.
  - Define drain resistance, trans conductance & Amplification factor of FET

79. What adder? With neat circuit diagram, Explain of half adder and give its truth table.
80. What adder? With neat circuit diagram, Explain of full adder and give its truth table.
- a. What a logic family? Mention the different logic families.
  - b. Explain the working of RTL NOR gate.
81. What a logic family? Mention the different logic families.
82. Explain the working of DTL NOR gate.
83. What a logic family? Mention the different logic families.
84. Explain the working of TTL NOR gate.
85. Draw the logic symbol and truth table for each of the following gates.
- a. Three Input OR gate
  - b. Two Input NAND gate
  - c. Three Input XOR gate.
86. a. State and prove a. Commutative and Associative property of Boolean algebra
- b. Distributive property of Boolean algebra



**KLE SOCIETY'S**  
**P. C. JABIN SCIENCE COLLEGE,**  
**AUTONOMOUS, CPE PHASE -III**  
AFFILIATED TO KARNATAK UNIVERSITY DHARWAD  
APPROVED BY UNIVERSITY GRANTS COMMISSION, NEW DELHI AND  
GOVERNMENT OF KARNATAKA  
**Accredited at 'A' Grade by NAAC**  
**VIDYANAGAR, HUBBALLI-580031**

---

**DEPARTMENT OF PHYSICS**

**BSc VI Semester Physics Paper – I**

**Solid State Physics & Nuclear Physics**

Question bank

**Crystal structure**

**Questions carrying 2 marks**

1. What is a crystal?
2. Define space lattice.
3. Define the terms basis and crystal structure.
4. Distinguish between space lattice and crystal structure.
5. What is bravais lattice?
6. What is meant by basis vectors and lattice translational vectors?
7. What are primitive & non-primitive cells?

or

Distinguish between primitive cell and non- primitive cell.

8. Define unit cell.

Or

What do you mean by a unit cell of the crystal?

9. Write down the number of molecules/atoms present in the unit cell of NaCl crystal.
10. What is the number of molecules/atoms present in the unit cell of simple cubic (SC) lattice?
11. What is the number of molecules/atoms present in the unit cell of BCC lattice?
12. What is the number of molecules/atoms present in the unit cell of FCC lattice?
13. Write down the number of molecules/atoms present in the unit cell of CsCl crystal.
14. What is the basic structure of NaCl lattice?
15. What is the basic structure of CsCl lattice?
16. What is meant by crystal symmetry?
17. Mention point symmetry operations.
18. Explain the meaning of n-fold rotation axis. What is the value of angle of rotation for 3-fold rotation axis?
19. Write down the coordination number of simple cubic (SC) lattice.
20. Deduce the coordination number of BCC lattice?

21. Deduce the coordination number of FCC lattice?
22. What is the value of atomic radius of simple cubic (SC) lattice?
23. What is the value of atomic radius of BCC lattice?
24. What is the value of atomic radius of FCC lattice?
25. Define lattice planes.
26. What are miller indices?

or

What do you mean by Miller indices of a crystal plane?

27. What are Miller indices? What do they signify?
28. Explain the method to determine the miller indices of a crystal plane
29. Deduce the Miller indices of a plane which intercepts at  $a$ ,  $b/2$ ,  $3c$  in a simple cubic unit cell.
30. The Miller indices of a plane in a simple cubic crystal are  $[123]$ . Find the coordinates of the plane.
31. A crystal plane produces intercepts  $4a$ ,  $b$ ,  $2c$  on X, Y and Z axes respectively. Find the Miller indices.
32. Write down the Miller indices for planes in the given set of intercepts  $(a, b/2, c)$ .
33. Find the miller indices of the crystal plane having intercepts of 1, 2 and 3 on the x, y and z axis respectively.
34. Find the miller indices if the plane in a crystal has intercepts in the ratio of  $4a$ ,  $5b$  and 0 on the X, Y and Z axis respectively.
35. For a simple cubic lattice of lattice parameter  $2.04\text{\AA}$ , calculate the spacing of lattice plane (212).
36. If the interplanar spacing for (321) plane is  $1.122\text{\AA}$  in the case of a cubic lattice. Calculate the lattice constant.

### Crystal X-ray diffraction

#### Questions carrying 2 marks

1. Explain origin of characteristic X-ray spectrum.
2. Write any two properties of continuous X-ray spectrum.
3. State Bragg's law of diffraction.
4. Write Bragg's equation for X-ray diffraction. Explain the terms.
5. Why for  $\lambda > 2d$ , Bragg's equation has no solution?
6. Mention X-ray diffraction methods.
7. Calculate the longest wavelength that can be analyzed by a rock-salt crystal of spacing
8.  $d=2.8\text{\AA}$  in the first order.
9. The spacing between the principle planes of NaCl crystal is  $2\text{\AA}$ , The first order Bragg's
10. Reflection occurs at an angle of  $10^\circ$ . What is the wavelength of X-ray?

### Free Electron Theory of Metals

#### Questions carrying 2 marks

1. Mention two basic assumptions made by Drude and Lorentz in case of free electron theory of

metals.

2. What do you mean by free electron gas?
3. Define drift velocity and its mobility of electron.
4. Write down the expression for thermal conductivity of metal. Explain the terms.
5. Write down the expression for electrical conductivity of metal. Explain the terms.
6. State Wiedemann-Franz law in case of metals.
7. Mention any two failures of classical free electron theory.
8. What are the assumptions made by Sommerfeld to explain the free electrons of metal?
9. What is Fermi level?
10. What is Fermi energy?
11. What do you mean by Fermi energy and Fermi level?
12. Mention any two advantages of Sommerfeld model of free electrons of metals.
13. Mention any two limitations of Sommerfeld model of free electrons of metals.
14. For copper at 20°C, electrical conductivity is  $5.81 \times 10^7$  SIU and thermal conductivity is 386 SIU. Calculate Lorentz number.
15. Calculate the Quantum mechanical value of Lorentz number. Given:  $k_B = 1.38 \times 10^{-23}$  J/K,  $e = 1.6 \times 10^{-19}$  C.
16. Fermi energy for gold is 5.54 eV. Calculate its Fermi temperature.

## Semiconductors

### Questions carrying 2 marks

1. Mention one difference between Sommerfeld model and Kronig-Penney model for free electron in solids.
2. What is the effective number of free electrons at absolute zero in case of (i) semiconductors and (ii) insulators.
3. Explain the concept of hole.
4. Explain the terms: (i) intrinsic semiconductor and (ii) extrinsic semiconductor.

or

What do you mean by intrinsic and extrinsic semiconductors?

5. What are n-type and p-type semiconductors?
6. Draw the energy band diagram for intrinsic semiconductor.
7. Draw the energy band diagram for n-type semiconductor.
8. Draw the energy band diagram for p-type semiconductor.
9. Define the terms (i) Valence band (ii) Conduction band of semiconductor
10. What do you mean by forbidden energy band gap of semiconductor?
11. How the mobility of charge carriers depends on temperature in a semiconductor?
12. What is Hall effect?
13. Define the terms (i) Hall voltage and (ii) Hall coefficient.
14. Write any two applications of Hall effect.
15. What is significance of Hall effect?



16. Determine the conductivity of pure silicon at 300K. Given that the concentration of carriers is  $1.6 \times 10^{10}$  per  $\text{cm}^3$  for silicon. The mobility of electrons is  $1500 \text{ cm}^2/\text{volt}\cdot\text{sec}$ , and that of holes is  $500 \text{ cm}^2/\text{volt}\cdot\text{sec}$ .
17. Calculate the Hall coefficient of sodium if the number of free electrons per unit volume is  $2.55 \times 10^{26}$ .

## Magnetic Materials

### Question carrying 2 marks

1. What are diamagnetics? Name few diamagnetic substances.
2. What are Paramagnetics? Name few Paramagnetic substances.
3. What are Ferromagnetics? Name few ferromagnetic substances.
4. Why do magnetic lines of force prefer to pass through ferromagnetic substances than through air?
5. What do you infer from the large value of the susceptibility of the material?
6. What happens, if an iron bar magnet is melted? Does it retain its magnetism? Justify.
7. Why does a Paramagnetic sample display greater magnetization when cooled?
8. Why do we use steel or alnico for making Permanent Magnets?
9. Mention two important applications of magnetic materials.
10. Define magnetic induction.
11. Define intensity of magnetization.
12. Define magnetic permeability.
13. Define magnetic susceptibility.
14. Show that  $\mu_r = (1 + \chi)$ , where  $\mu_r$  = relative permeability and  $\chi$  is magnetic susceptibility.
15. What is magnetostriction?
16. Define coercivity and retentivity.
17. Find the relative permeability of a ferromagnetic material if field of strength  $200 \text{ Am}^{-1}$  produces a magnetization of  $3300 \text{ Am}^{-1}$  in it.
18. The magnetic susceptibility of silicon is  $-0.5 \times 10^{-5}$ . What is the intensity of magnetization in a magnetic field of intensity  $9.9 \times 10^4 \text{ Am}^{-1}$ ?
19. An iron bar is subjected to a magnetizing field  $1200 \text{ Am}^{-1}$ . If susceptibility of iron is 599. Calculate (i)  $\mu$  and (ii) B.

## Superconductivity

### Questions carrying 2 marks

1. What is superconductivity?
2. Give two main characteristics of superconductors.
3. What is Meissner effect?
4. What are superconductors?
5. What is the difference between a conductor cooled to  $0^\circ \text{ K}$  and a superconductor?
6. Superconductor cooled below transition temperature in an external magnetic field become perfect diamagnet. Justify.

7. What is critical field and what is its value at the critical temperature?
8. What is critical temperature? Write the relation between critical temperature and critical field.
9. What is vortex state of a superconductor?
10. What high  $T_c$  superconductors? Give one example.
11. What is maglev vehicle? Mention its principle.
12. Show that magnetic susceptibility of superconductor is -1.
13. What is the isotope effect in superconductor?
14. What is the pressure effect in superconductor?
15. What is the effect of temperature on entropy of superconductor?
16. What are type-I & type-II superconductors?
17. Distinguish hard and soft superconductors.
18. What are SQUIDS?
19. What is perovskite structure with respect to the high  $T_c$  superconductors?
20. What are the hurdles to produce superconductors at room temperature?
21. Mercury isotopic mass is 199.5 at 4.185K. Calculate its critical temperature when its isotopic mass changes to 203.4 amu.
22. Critical temperature of superconductor is 10 K at a pressure of 1 mm of Hg. Calculate critical temperature of the material at a pressure of 5 mm of Hg.

**5 mark questions:**

**Crystal structure**

1. Describe briefly the seven systems of crystals.
2. What do you mean by Bravais lattices? Describe briefly the seven systems of crystals.
3. Name the seven crystal systems. Mention the number of Bravais lattices in cubic system.
4. Write a note on Bravais lattice.
5. What is a Bravais lattice? What are the different space lattices in the cubic system? How many lattice points per unit cell are there in each of these lattices?
6. Write a note on Bravais lattice.
7. Define crystal systems and give their characters.
8. What are Miller indices of a plane in crystal? How are they determined?
9. What are lattice planes of crystal? How they are represented in terms of Miller indices?
10. What are miller indices? Obtain an expression for the interplanar spacing in terms of miller indices.
11. Describe the crystal structure of NaCl. Explain clearly how this structure differs from that of CsCl. Give the coordinates of the atoms within *fcc* lattice.
12. The density of NaCl is  $2.16 \times 10^3 \text{ kg/m}^3$ . Find the lattice constant, if the NaCl has *fcc* lattice. (Given: Avogadro's No.  $6.023 \times 10^{26} / \text{kg mol}$ , molecular weight of NaCl = 58.5)
13. NaCl crystal has *fcc* structure. The density of NaCl is  $2.18 \times 10^3 \text{ kg m}^{-3}$  calculate the distance between two adjacent atoms (atomic weight of Na = 23 and that of Cl = 35.5)
14. Calculate the density of copper if its atomic weight is 63.54 and lattice constant is  $3.61 \text{ \AA}$ ,

it has *fcc* structure.

15. In a tetragonal lattice  $a=b=2.8\text{\AA}$ ,  $c=1.8\text{\AA}$ . Calculate the lattice spacing between the planes (222).
16. A substance with face centered cubic lattice has density  $6.25\text{ kg m}^{-3}$  & molecular weight 60.2. Calculate the lattice constant, Avogadro's number =  $6.02 \times 10^{26}/\text{kg mol}$
17. Show that for a simple cubic lattice  $d_{100} : d_{110} : d_{111} = \sqrt{6} : \sqrt{3} : \sqrt{2}$
18. Calculate the lattice constant of NaCl crystal from the following data.  
Molecular weight of NaCl  $M=58.5$   
Avogadro number  $N = 6.02 \times 10^{26}$   
Density of NaCl  $\rho = 2180\text{ kg m}^{-3}$
19. Deduce the Miller indices of a plane which cuts off intercepts in the ratio  $1a:3b:-2c$  along the three axes, where  $a$ ,  $b$  and  $c$  are primitives.
20. In a crystal primitives are  $1.2\text{\AA}$ ,  $1.8\text{\AA}$  and  $2.0\text{\AA}$ , a plane (231) cuts an intercept  $1.2\text{\AA}$  on the X-axis. Find the corresponding intercepts on Y-axis and Z-axis.
21. Lead is a face centered cube with an atomic radius of  $1.746 \times 10^{-10}\text{ m}$ . Calculate the spacing between planes (i) 200 plane (ii) 220 plane.

## Crystal X-ray diffraction

1. Explain salient features of X-ray spectra.  
Or  
Give an account of X-Ray Spectra
2. Why X-rays get diffracted by crystals? Derive expression for Bragg's law of X-ray diffraction.
3. State and explain Bragg's law of X-Ray diffraction. Derive expression for it. Why we can not use visible light for diffraction in crystals?
4. Describe Bragg's x-ray spectrometer.
5. A beam of X-rays of  $\lambda = 0.842\text{\AA}$  is incident on a crystal at a grazing angle of  $8^{\circ}35'$  when the first - order Bragg's reflection occurs. Calculate the facing angle for 3rd order reflection.
6. Monochromatic x-rays of  $\lambda = 1.5\text{\AA}$  are incident on a crystal face having all interplanar spacing of  $1.6\text{\AA}$ . Find the various orders in which Bragg's reflections take place.
7. Find the various possible orders of reflection from a crystal whose lattice constant is  $1.4\text{\AA}$ .
8. The wavelength of X - rays is  $1.28\text{\AA}$ .
9. What wavelength in a beam containing the range  $0.2\text{\AA}$  and  $1\text{\AA}$  will be reflected when incident at  $9^{\circ}$  upon the cube face of a crystal of a rocksalt crystal? Given  $d = 2.814\text{\AA}$ .
10. Monochromatic X-rays incident on a crystal of interplanar spacing  $0.28\text{ nm}$  produces Bragg's reflection of certain order at glancing angle of  $18^{\circ}$ . When the same X-rays are incident on another crystal of interplanar spacing  $0.34\text{ nm}$ , the reflection occurs at  $30^{\circ}$ . calculate the wavelength of X-rays.
11. An X-ray tube operates at  $30\text{ kV}$  emits a continuous X-ray spectrum with a short wavelength limit  $\lambda = 0.414 \times 10^{-10}\text{ m}$ . Find the Planck's constant. (Given  $e = 1.6 \times 10^{-19}\text{ C}$  and  $C = 3 \times 10^8\text{ m/s}$ ).

## Free Electron Theory of Metals

1. Discuss Drude and Lorentz (classical) free electron theory of metals.

2. Discuss the failures of classical free electron theory.
3. State Wiedemann-Franz Law and arrive at the equation for classical Lorentz number. Compare the classical, Quantum mechanical and experimental value of Lorentz number.
4. Using the free electron model derive the expression for the electron conductivity in metals.
5. Using the free electron model derive the expression for the thermal conductivity in metals.
6. Explain the Sommerfeld's Quantum mechanical free electron theory of metals.
7. Explain the merits and limitations of Sommerfeld model of free electrons of metals.
8. Calculate the electrical conductivity of copper assuming that each atom contribute one free electron.

Given: atomic weight of Cu=63.54  
 density of copper =  $8.93 \times 10^3 \text{ kgm}^{-3}$   
 mass of electron =  $9.1 \times 10^{-31} \text{ kg}$   
 relaxation time of electrons =  $2.48 \times 10^{-14} \text{ s}$

9. Calculate the Fermi energy of copper assuming that each atom contributes one free electron.

Given: Atomic weight of copper = 63.54  
 Density of copper =  $8.93 \times 10^3 \text{ kgm}^{-3}$   
 Avogadro's number =  $6.02 \times 10^{26}$  per kmol  
 Mass of electron =  $9.1 \times 10^{-31} \text{ kg}$ .  
 Planck's constant =  $6.63 \times 10^{-34} \text{ Js}$

10. Calculate the Fermi energy of sodium assuming that the metal has one free electron per atom.

Given:  $h = 6.63 \times 10^{-34} \text{ Js}$   
 Mass of electron =  $9.1 \times 10^{-31} \text{ kg}$ .  
 Density of Sodium =  $9.73 \text{ kg/m}^3$   
 Atomic Weight of Sodium = 22.99 amu.  
 Avogadro's number =  $6.02 \times 10^{26}$  per kmol

11. The density of zinc of valency 2 is  $7130 \text{ kgm}^{-3}$  and its atomic weight is 65.4. Calculate its Fermi energy. The effective mass of a free electron in zinc crystal is  $7.7 \times 10^{-31} \text{ kg}$ .  
 Avogadro's number =  $6.02 \times 10^{26}$  per kmol

### Semiconductors

1. Based on the energy band diagram distinguish between conductors, insulators and semiconductors.
2. Derive the expression for electron concentration for an intrinsic semiconductor.
3. Give the theory of experimental determination of energy gap of semiconductor.
4. Derive an expression for Hall coefficient.
5. Derive an expression for electrical conductivity of an intrinsic semiconductor.
6. Outline band theory of solids.
7. Describe Hall effect in semiconductors.
8. What is Hall effect? Write the applications of Hall coefficient.
9. Find the concentration of holes and electrons in a p-type Germanium at 300 K, if the conductivity is 100 per  $\Omega \text{ cm}$ . Also find these values for n-type silicon, if the conductivity is 0.1 per  $\Omega \text{ cm}$ .

Given that for Ge,  $n_i = 2.5 \times 10^{13} / \text{cm}^3$ ;  $\mu_n = 3800 \text{ cm}^2 / \text{V.s}$ ;  $\mu_p = 1800 \text{ cm}^2 / \text{V.s}$   
 for Si,  $n_i = 1.5 \times 10^{13} / \text{cm}^3$ ;  $\mu_n = 1300 \text{ cm}^2 / \text{V.s}$ ;  $\mu_p = 500 \text{ cm}^2 / \text{V.s}$

10. A semiconductor has the electron concentration  $0.45 \times 10^{12} \text{ m}^{-3}$  and hole concentration  $5 \times 10^{20} \text{ m}^{-3}$ . Find its conductivity.  
 Given: hole mobility =  $0.048 \text{ m}^2/\text{V.s}$  ; Electron mobility =  $0.135 \text{ m}^2/\text{V.s}$
11. The resistance of a semiconductor is  $4.5 \Omega$  at  $20^\circ \text{C}$  and  $2.0 \Omega$  at  $32^\circ \text{C}$ . Calculate the energy gap. Boltzmann constant,  $k = 1.37 \times 10^{-23} \text{ JK}^{-1}$ .
12. The energy gap in germanium is  $0.75 \text{ eV}$ . Compare the intrinsic conductivities of germanium at  $27^\circ \text{C}$  and  $57^\circ \text{C}$ . Boltzmann constant  $k = 8.6 \times 10^{-6} \text{ eV}$ .
13. In an intrinsic GaAs, the electron and hole mobilities are  $0.85$  and  $0.04 \text{ m}^2/\text{V.s}$ . respectively and the corresponding effective masses are  $0.068m_0$  and  $0.5m_0$  respectively, where  $m_0$  is rest mass of an electron. Given the energy band gap at  $300\text{K}$  as  $1.43 \text{ eV}$ , determine the intrinsic carrier concentration and mobility.
14. For an intrinsic semiconductor with a gap width of  $1 \text{ eV}$ . Calculate the position of Fermi level at  $T=0\text{K}$  and at  $T=300\text{K}$ , if  $m_h^* = 6m_e^*$ , where  $m_h^*$  and  $m_e^*$  are effective masses of hole and electron respectively.
15. Calculate the Hall voltage and Hall coefficient in a Ge crystal of thickness  $0.6 \text{ mm}$ , when A magnetic field of  $0.8 \text{ T}$  is applied. The current density is  $350 \text{ Am}^{-2}$  and electron density is  $3 \times 10^{23} \text{ m}^{-3}$ .
16. A metal strip carrying a current of density  $5 \text{ Am}^{-2}$  is applied with a magnetic field of  $2 \text{ T}$  normally. The Hall voltage developed is found to be  $6.3 \text{ V}$ . If the thickness of the strip is  $3.5 \times 10^{-3} \text{ m}$ , calculate electron density and Hall field ( $e = 1.6 \times 10^{-19} \text{ C}$ ).
17. Mobilities of electrons and holes in a sample of intrinsic silicon at room temperature are  $0.36 \text{ m}^2 \text{V}^{-1} \text{s}^{-1}$  and  $0.1736 \text{ m}^2 \text{V}^{-1} \text{s}^{-1}$  respectively. Calculate electrical conductivity of silicon. (Given: electron and hole densities are equal to  $2.5 \times 10^{16} \text{ m}^{-3}$ ).
18. Mobilities of electrons and holes in a sample of intrinsic germanium at room temperature are  $0.54 \text{ m}^2 \text{V}^{-1} \text{s}^{-1}$  and  $0.18 \text{ m}^2 \text{V}^{-1} \text{s}^{-1}$  respectively. If electron and hole densities are equal to  $3.6 \times 10^{19} \text{ m}^{-3}$ . Calculate germanium conductivity and resistivity.

## Magnetic Materials

### Q. No II Questions carrying 5 marks

1. Distinguish between diamagnetic and paramagnetic materials.
2. What are paramagnetic, diamagnetic and ferromagnetic materials? Explain.
3. State Properties of Paramagnetic substances.
4. State Properties of diamagnetic substances.
5. State Properties of ferromagnetic substances.
6. How are materials classified according to their behavior in magnetic field? Why does the magnetization of a paramagnetic substance increase on cooling?
7. Write a note on applications of magnetic materials.
8. A magnetic field of  $1800 \text{ Am}^{-1}$  produces a magnetic flux of  $3 \times 10^{-5} \text{ Wb}$  in an iron bar of cross sectional area  $0.2 \text{ cm}^2$ . Calculate permeability.
9. The magnetic flux density and intensity of magnetizing field in sample of magnetic material are  $1 \text{ T}$  and  $3 \times 10^3 \text{ Am}^{-1}$  respectively. Find permeability and susceptibility of the medium.

10. Describe Gouy's method to determine susceptibility of paramagnetic substance.

## Superconductivity

### Questions carrying 5 marks

1. Explain the concept of superconductivity on the basis of free electron model for metals.
2. Enlist the properties of superconductors.
3. Discuss the effect of critical magnetic field on critical transition temperature using magnetic phase diagram.
4. Write a note on Meissner effect.
5. Explain Meissner effect. How it contradicts classical Maxwell theory?
6. Explain Meissner effect. How it leads to the superconductor as perfect diamagnetic?
7. Describe an experiment to demonstrate Meissner effect.
8. Write a note on type –I and type-II superconductors.

or

Explain type – I and type – II superconductors.

9. Distinguish between type – I and type – II superconductors. Write any two applications of superconductors.
10. Write on high temperature superconductors.

or

Briefly account for high temperature superconductors.

11. Enlist applications of superconductors.
12. The critical temperature of a superconductor at zero magnetic field is  $T_c$ . Determine the temperature at which the critical field becomes half of its value at 0K.
13. The critical fields at 6K and 8K for NbTi alloy are  $7.616 \times 10^6$  and  $4.284 \times 10^6 \text{ Am}^{-1}$  respectively. Determine the transition temperature and critical field at 0K.
14. At 6K critical field is  $5 \times 10^3 \text{ Am}^{-1}$ . Calculate the transition temperature, where magnetic field is  $2 \times 10^4 \text{ Am}^{-1}$  at 0K.
15. A superconductor with  $T_c = 3.5\text{K}$  has a critical magnetic field of  $3.2 \times 10^3 \text{ Am}^{-1}$ . What would be the value of critical field at 2.5K?

### 10 mark questions:

#### Crystal structure

1. Describe the seven crystal systems and 14 Bravais lattices with suitable diagrams.
2. What are Miller indices? Describe the procedure to determine them. Derive an expression for the spacing between planes having similar Miller indices.

#### Crystal X-ray diffraction

1. Describe Bragg's x-ray spectrometer and explain how it is used to determine the structure of the crystal.

### **Free Electron Theory of Metals**

1. a) Discuss classical free electron model.  
b) Obtain an expression for electrical conductivity of metals.
3. a) Derive an expression for electrical conductivity in case of free electrons of metals.  
b) Deduce Wiedemann-Franz Law and compare classical value and experimental value of Lorentz number.
4. Discuss Sommerfeld's quantum mechanical free electron theory of metals.

### **Semiconductors**

1. a) Describe the formation of energy bands in solids.  
b) Explain how it helps to classify the materials as conductors, insulators and semiconductors.

OR

- Explain the formation of energy bands in solids and discuss the classifications.
2. Derive an expression for electrical conductivity of an intrinsic semiconductor.

### **Magnetic Materials**

#### **Questions carrying 10 marks**

1. Discuss the classification of magnetic materials and distinguish between paramagnetic and diamagnetic materials.
2. How do you account for origin of magnetic moment in a magnetic material? Explain the classification of materials based on their behavior in a magnetic field.
3. Discuss Langevin's classical theory of Paramagnetism.

Note: combining 5 marks questions, 10 marks questions may be framed.

### **Superconductivity**

#### **Questions carrying 10 marks**

1. Explain Meissner effect. How it contradicts classical Maxwell theory? Describe the experiment to demonstrate Meissner effect.
2. Explain the concept of superconductivity on free electron model. Discuss the effect of critical field on critical temperature using magnetic phase diagram.
3. Write a note on a) High-T<sub>c</sub> superconductors (b) Applications of superconductors.

## Nuclear Physics

### 2 mark Questions

#### Radioactive radiations and Scattering $\alpha$ of Particles

1. What is the nature of  $\alpha$ - &  $\beta$ -particles?
2. With which elements/particles the  $\alpha$  rays,  $\beta$  rays and  $\gamma$  rays are identified?
3. Mention common properties of radiations.
4. Define impact parameter & closest distance of approach
5. State postulates of Rutherford's theory of  $\alpha$  -ray scattering
6. Mention the factors affecting the probable number of  $\alpha$  particles to be scattered?
7. Mention the changes in mass number and atomic number with emission of  $\gamma$  radiation. What will happen to atomic radius?

#### Nuclear Models

8. Write an expression of semi empirical formula for the BE.
9. What are magic numbers?
10. Mention two examples of doubly magic elements.
11. Who proposed the liquid drop model of a nucleus?
12. Mention the merits of liquid drop model.
13. Mention the demerits of liquid drop model.

#### Nuclear Forces

14. What is the nature of nuclear force?
15. Are the nuclear forces (i) charge independent (ii) exist beyond the radius of the nucleus?
16. What is the mass and charge of pion?
17. Who proposed the meson theory of nuclear forces?

#### Nuclear Reactions

18. What is the nuclear reaction? Give an example.
19. Mention types of nuclear reactions.
20. What are endoergic & exoergic reactions?
21. What is Q-value of nuclear reaction?
22. What do you mean by nuclear transmutation?
23. What are pickup reactions? Give an example.
24. Mention knockout reaction with an example.
25. What are thermonuclear reactions?
26. Complete the following reaction
  - (i)  ${}_4\text{Be}^9 + ? = {}_6\text{C}^{12} + {}_1\text{n}^0$
  - (ii)  $\text{n} + \pi^+ \rightarrow ?$
27. What is the particle 'X' in the following nuclear reactions?



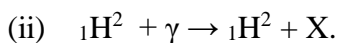

### Nuclear Fission and Fusion

28. Mention types of nuclear fission.
29. Explain P-P cycle.
30. What is Nuclear Fission?
31. What is Nuclear Fusion?
32. Define critical parameter. Mention its value for nuclear stability against spontaneous emission.
33. Calculate loss of mass into energy in the following reaction  ${}_1\text{H}^2 + {}_1\text{H}^2 = {}_2\text{He}^4$

Given: mass of  ${}_1\text{H}^2 = 2.01402\text{amu}$

Mass of  ${}_2\text{He}^4 = 4.002603\text{amu}$

### Nuclear Instruments

#### Q. No I Questions carrying 2 marks

1. What is mass spectrograph?
2. Why the beam of positive ion deflected by electrified are allowed to pass through the magnetic field in Aston's mass spectrograph?
3. What are the advantages of Aston's mass spectrograph?
4. Enlist the limitations of Aston's mass spectrograph.
5. What is the function of velocity selector in Bainbridge's mass spectrograph?
6. What is dead time and recovery time with respect to GM counter?
7. Define efficiency of GM counter.
8. What is quenching? Why it is necessary?
9. What is plateau region?
10. Enlist advantages of GM counter.
11. Mention disadvantages of GM counter.
12. Why GM counter cannot detect neutrons?
13. What is the principle of scintillation counter?
14. What is spintharoscope?
15. What is dynode? What is its function?
16. What is the function of photomultiplier tube?
17. What is nuclear emulsion?
18. Compare nuclear emulsion and optical emulsion.
19. Mention the applications of nuclear emulsion.
20. Enlist advantages of nuclear emulsion.
21. State the betatron condition.
22. Mention the condition of resonance in a cyclotron.

### 5 mark Questions

#### Radioactive radiations and Scattering $\alpha$ of Particles

1. Mention the properties of  $\alpha$ -,  $\beta$ - &  $\gamma$  radiations
2. Deduce an expression of impact parameters
3. Obtain Rutherford's scattering formula.
4. Define impact parameter, angle of scattering and closest distance of approach for  $\alpha$ -ray scattering. Mention the expression for impact parameter.
5. Find the impact parameter and cross section for an  $\alpha$  particle of energy 7.68MeV, scattered by a thin gold foil ( $Z=79$ ) of thickness  $6 \times 10^{-12}$  m for scattering angle of  $90^\circ$ . Also calculate the ratio of number of  $\alpha$  particles scattered at an angle of  $90^\circ$  to the total number of incident  $\alpha$  particles.  
Given  $A=197$ ,  $\rho=19.3 \times 10^3 \text{kgm}^{-3}$ , Avagadro's number= $6.02 \times 10^{26}$
6. An  $\alpha$  particle of energy 5MeV is scattered through  $180^\circ$  by a fixed  ${}_{92}\text{U}$  nucleus.
7. The number of  $\alpha$  particles scattered at an angle of  $10^\circ$  is 106. What will be the number of scattered  $\alpha$  particles at an angle of  $90^\circ$  and  $180^\circ$ ?

### Nuclear Models

8. Explain liquid drop model.  
Or  
Discuss the assumptions of liquid drop model.
9. Deduce semi empirical mass formula.
10. Write a note on semi empirical mass formula.
11. Explain shell model.  
Or  
Write a note on shell model of nucleus.
12. Compare shell model & liquid drop model.
13. Explain nuclear fission on the basis of the liquid drop model.
14. What are magic number nuclei? How does the shell model explain the existence of magic numbers 2, 8 and 20.

### Nuclear Forces

15. Explain Meson theory of nuclear forces.
16. What are nuclear forces? Write a note on the meson theory of nuclear forces.

### Nuclear Reactions

17. Mention types of Nuclear reactions with examples.
18. Deduce the condition for endoergic reaction to take place.
19. Derive the relation between Q-value and threshold energy of endoergic reaction.
20. Explain nuclear transmutation with examples.
21. State conservation laws governing nuclear reactions with examples.
22. Find Q-value of the reaction  ${}_{3}\text{Li}^7(\text{P } \alpha){}_2\text{He}^4$ , if mass of Li, P and  $\alpha$  are 7.01822, 1.00814 and 4.00387amu.
23. Compute Q-value and threshold energy of the nuclear reaction  ${}_{7}\text{N}^{14}(\text{n, d}){}_{6}\text{C}^{13}$ .  
Given: Mass of  ${}_{7}\text{N}^{14} = 14.003074 \text{amu}$

Mass of neutron=1.008665amu

Mass of deuterium= 2.014102amu

Mass of  ${}^6\text{C}^{13}$ =13.003354

24. Calculate the Q-value and threshold energy of  $\alpha$  particle in nuclear reaction  ${}^7\text{N}^{14} (\alpha, \text{P}) {}^8\text{O}^{17}$ .  
Given:  $M_a=4.00387$ ,  $M_X=14.00753$ ,  $M_b=1.00814$  and  $M_y=17.00450$ amu.
25. Compute mass of oxygen and minimum kinetic energy of  $\alpha$  particle for the endoergic reaction  ${}^7\text{N}^{14} (\alpha, \text{P}) {}^8\text{O}^{17}$  Given:  $M_a=4.00387$ ,  $M_X=14.00753$ ,  $M_b=1.00814$  and  $Q= -1.154$
26. Calculate minimum energy of  $\gamma$  required to disintegrate a deuteron into a proton and neutron.  
Given:  $M_p=1.00759$ ,  $M_n=1.00898$ ,  $M_d=2.01471$ amu
27. Find the mass of carbon in a nuclear reaction  ${}^7\text{N}^{14} + {}^0_1\text{n}^1 \rightarrow {}^6\text{C}^{14} + {}^1_1\text{H}^1 + 0.55\text{Mev}$ .
28. Determine the product nuclei and Q-value of the reaction  ${}_{13}\text{Al}^{27} (\text{d}, \alpha)$ , if mass of  ${}_{13}\text{Al}^{27}$ ,  ${}_{13}\text{Al}^{27}$ ,  $\alpha$  and d are 26.9901, 24.9936, .0039 and 2.0147

### Nuclear Fission and Fusion

29. Explain Bohr wheeler theory of nuclear fission.
30. Explain C-N cycle.
31. Write a note on Hydrogen bomb.
32. Calculate the energy released by the fission of 1kg of u-235, if energy released per fission is 200Mev and Avogadro's number= $6.02 \times 10^{26}$
33. A reactor is developing energy at the rate of  $32 \times 10^{26}$  watts. How many atoms of u-235 undergo
34. fission per second? Assume energy released per fission is 200Mev. Also find the mass of uranium.
35. Find the energy released during the fusion of two deuterons into helium and a neutron, if mass of deuteron, helium and neutron are 2.014102, 3.016049 and 1.008656amu.

### Nuclear Instruments

#### Q. No II Questions carrying 5 marks

1. Describe the construction and working of Aston's mass spectrograph.
2. Describe the principle, construction and working of Bainbridge mass spectrograph.
3. Describe construction and working of GM counter.
4. Describe the construction and working of scintillation counter.
5. Write a note on nuclear emulsion.
6. With a neat diagram explain the construction and working of cyclotron.
7. Obtain expression for length of  $n^{\text{th}}$  cylinder in a linear accelerator.
8. Describe the principle, construction and working of Cyclotron.
9. In a betatron, magnetic flux density within the stable orbit changes at the rate of  $16\text{WbS}^{-1}$ . Calculate the energy of electron which undergoes  $2 \times 10^6$  revolutions per second.
10. In a linear accelerator, proton accelerated thrice by a potential of 40kV, leaves a tube and enters an accelerating space of length 30 cm before entering the next tube. Calculate the frequency of r.f. voltage and length of the tube entered by the proton.
11. Deuterons in a cyclotron describe a circle of radius 0.28 m just before emerging out the Dee's.

The frequency of applied emf is 20 MHz. Find the flux density of the magnetic field and velocity of Deuterons emerging out of cyclotron. Mass of the Deuteron is  $3.32 \times 10^{-27}$  kg and charge is  $1.6 \times 10^{-19}$  C.

### 10 mark Questions

#### Radioactive radiations and Scattering $\alpha$ of Particles

1. What are the assumptions of Rutherford model? Deduce the relation between impact parameter and smallest distance of approach.
2. Deduce an expression for the impact parameter and hence obtain Rutherford's scattering formula.

#### Nuclear Models

3. List the comparative properties of liquid drop and nucleus. Deduce the semi-empirical mass formula.
4. Deduce semi-empirical mass formula of binding energy and explain specific binding energy curve.
5. Explain liquid drop model and obtain semi-empirical mass formula.

#### Nuclear Reactions

6. Mention types of Nuclear reactions with examples.
7. What is Q-value of nuclear reaction? Deduce expression of Q- Value of nuclear reaction.

#### Nuclear Instruments

#### Q. No III Questions carrying 10 marks

1. Describe the construction and working theory of Aston's mass spectrograph. Develop the theory to determine the mass of the particles.
2. Describe the construction and working theory of Aston's mass spectrograph. How it is used in detection of isotopes? What are its advantages?
3. Describe the principle, construction and working of Bainbridge mass spectrograph. How the nuclear mass is determined using this?
4. Discuss in detail the construction and working of a GM counter. What do you mean by quenching of GM counter? What is its necessary?
5. Describe with neat diagram the construction and working of a GM counter. Explain paralyzing time of GM counter.



KLE SOCIETY'S

**P. C. JABIN SCIENCE COLLEGE,**

**AUTONOMOUS, CPE PHASE -III**

AFFILIATED TO KARNATAK UNIVERSITY DHARWAD  
APPROVED BY UNIVERSITY GRANTS COMMISSION, NEW DELHI AND  
GOVERNMENT OF KARNATAKA

**Accredited at 'A' Grade by NAAC**

**VIDYANAGAR, HUBBALLI-580031**

---

**DEPARTMENT OF PHYSICS**

B.Sc VI SEM

PHYSICS PAPER-II

**QUESTION BANK**

**2 Marks**

**Unit-I ATOMIC SPECTRA:**

1. Write the two drawbacks of Thomson's atom model.
2. Write the postulates of Rutherford nuclear atom model.
3. What are the limitations of Rutherford nuclear atom model?
4. What are postulates of Bohr's atom model?
5. Discuss limitations of Bohr's theory.

Or

Discuss shortcomings of Bohr's theory.

6. Name spectral series of hydrogen atom.
7. Name the line and region when an electron jumps from  $n=4$  to  $n=2$  of hydrogen atom.
8. Name the line and region when an electron jumps from  $n=3$  to  $n=2$  of hydrogen atom
9. Write the postulates of Sommerfeld's atom model.
10. What is relativistic atom model?
11. What are the drawbacks of Sommerfeld's atomic model?
12. Mention the new concept introduced in the vector atom model.
13. What do you mean by space quantization?
14. What is spin quantization?
15. In what way Sommerfeld atomic model differs from Bohr's model.
16. Draw the vector diagram of space quantization for 'p' electrons.
17. Draw the vector diagram of space quantization for 's' electrons.
18. Mention the four quantum numbers of vector atom model.
19. What is the limit for number of sub shell in shell?
20. What is the limit for number of electron in shell?
21. State Pauli's exclusion principle.
22. Name any two elements which have single valance electron.

23. What are alkali metals? Give one example.
24. Write any two characteristics of spectra of alkali metals.
25. What are alkaline earth metals? Give one example.
26. Write any two elements which have two valence electrons.
27. Write any two characteristics of spectra of alkaline earth metals.
28. Define Critical potentials.
29. What is excitation potential?
30. What is ionization potential?
31. Write the principle of Franck- Hertz experiment.
32. Calculate the ionization potential of the hydrogen atom taking  $h=6.625 \times 10^{-34}$  Js,  $e= 1.6 \times 10^{-19}$  C and  $m=9.1 \times 10^{-31}$  Kg.
33. Calculate the excitation potential of the mercury atom given the wave length of the emitted radiation, when the excited atom returned to its normal state is  $2531 \text{ \AA}$

### **VECTOR MODEL OF THE ATOM**

34. Draw the vector diagram of LS coupling for two electrons.
35. Draw the vector diagram of jj coupling for two electrons.
36. Mention the expression for magnetic momentum of the electron due to orbital and spin motion.
37. Mention any two differences between LS coupling & JJ coupling

### **MAGNETIC FIELD EFFECT ON LIGHT**

38. What is Larmor's precession?
39. Why Zeeman effect is called magneto-optical phenomenon?
40. What is Zeeman effect?
41. What is normal Zeeman effect?
42. Mention the expression for the magnetic interaction energy.
43. What is anomalous Zeeman effect?
44. Write expressions for normal Zeeman shift in terms of frequency and wavelength.
45. Write the expression for angular frequency of Larmor's theorem and describe the symbols.
46. Write the expression for total magnetic moment in anomalous Zeeman Effect.
47. What is Lorentz unit?
48. Draw the energy level diagram for sodium D lines with necessary spectral terms.

### **UNIT-II MOLECULAR SPECTRA**

49. Write any two uses of pure rotational spectra of a diatomic molecule.
50. Write the selection rules for the rotational spectra of a molecule.
51. Write any two differences between atomic & molecular spectra?

52. Write any two general features of line spectra.
53. Mention the different types of spectra of a molecule.
54. Write the expression for the rotational energy of a diatomic molecule & explain the symbols.
55. In which region of the electromagnetic spectrum, rotational spectrum is obtained.
56. Write any two general features of band spectra.
57. What are incandescent sources? Give example.
58. What are luminous gas sources? Give example.
59. Write the frequency condition for vibrational spectra and explain the terms. Calculate the inter nuclear distance or bond length if moment of inertia of the molecule is  $1.38 \times 10^{-17} \text{ Kg m}^2$  & reduced mass  $\mu = 1.58 \times 10^{-27} \text{ Kg}$ .
60. Determine the value of rotational constant for the HF molecule. If the moment of inertia of the molecule is  $1.38 \times 10^{-27} \text{ Kg m}^2$ .

### **RAMAN EFFECT**

61. What is Rayleigh scattering?
62. What is scattering of light? Mention two types of scattering.
63. What are coherent and incoherent scattering?
64. What is Raman scattering?
65. What is the difference between Rayleigh & Raman scattering?
66. Mention any two characteristics of Raman lines.
67. Write any two application of Raman effect.
68. What are Stokes & anti Stokes lines?

### **UNIT-III LASER AND HOLOGRAPHY**

69. What is LASER?
70. What do you mean by optical pumping?
71. Define Einstein's A and B coefficients.
72. What is stimulated emission?
73. Write the expression for Einstein's A and B coefficients.
74. Mention different types of pumping.
75. What is spontaneous emission?
76. Define the term population inversion.
77. Write the characteristics of Laser light.
78. Write any two medical applications of Laser.
79. Write any two Industrial applications of Laser.
80. Write any two military applications of Laser
81. What is Lasing transition?

82. What is induced absorption?
83. Write any two types of Laser.
84. Write any two uses of holography.
85. What is holography?
86. What is metastable state?
87. Write the principle of holography.

### **FIBRE OPTICS**

88. What is optical fibre?
89. What is coherent bundle?
90. Write any two applications of optical fibre.
91. What is numerical aperture in fiber optics?
92. Mention the types of optical fibre.
93. Write the expression for numerical aperture of fiber with usual notations.
94. Define acceptance angle in optical fibre.
95. What is core in optical fibre?
96. What is cladding in optical fibre?
97. On what factors numerical aperture depends?
98. Write any two differences between step index and multimode.
99. Write any two differences between graded index and multimode.
100. Write any two differences between graded index and monomode.

### **5 Mark Questions**

#### **Unit-I ATOMIC SPECTRA**

1. Write a note on Rutherford's atom model.
2. Write a note on Bohr's theory of nuclear atom model.
3. Write a note on Sommerfeld's relativistic atom model.
4. The velocity of an electron varies in its elliptical orbit. Justify.
5. State and explain the significance of four quantum number. How are they interrelated?
6. What is space quantization? Explain.
7. Explain the need for introducing the concept of electron spin.
8. Write note on vector atom model.



9. Explain with suitable example how Pauli's exclusion principle gives the logical reasoning of grouping of electron in shells and sub shells.
10. Explain electron configuration of an atom.
11. What are alkali spectra? Explain the characteristic of spectra.
12. What are alkaline earth metal spectra? Explain characteristic.
13. Based on Pauli's exclusion principle show that maximum number of electron in  $n^{\text{th}}$  orbit is  $2n^2$ .
14. The wavelength of first line in Balmer series is  $6563\text{\AA}$ . calculate the wavelength of the second line Lyman series.
15. Given that the spectral term corresponding to the ionization potential of energy atom is  $84178.5/\text{cm}$ . calculate the ionization potential of mercury atom.
16. Calculate (i) Ionization potential (ii) First excitation potential of the hydrogen atom taking  $h=6.625 \times 10^{-34}\text{Js}$ ,  $e=1.6 \times 10^{-19}\text{C}$  and  $m=9.1 \times 10^{-31}\text{Kg}$ .
17. In Stern Gerlach experiment silver atoms traverse a distance of  $0.1\text{m}$  in a non homogeneous magnetic field of field gradient  $55\text{Tm}^{-1}$ . If the velocity of silver atom is  $450\text{ms}^{-1}$ . Calculate the separation between the traces on the photographic plate. Given  $\mu_B=9.2 \times 10^{-24}\text{JT}^{-1}$ .
18. For an orbital electron with  $l=2$  calculate the possible values of  $j$  and mention the corresponding values of  $m_j$ .

### **VECTOR MODEL OF THE ATOM**

19. Explain different coupling schemes with an example.
20. Explain spin orbit interaction due to single valence electron.
21. Write note on LS coupling.
22. Write note on jj coupling.
23. Explain LS coupling scheme with vector diagram.
24. Explain jj coupling scheme with vector diagram.
25. Derive an expression for magnetic momentum due to orbital motion of the electron.

### **MAGNETIC FIELD EFFECT ON LIGHT**

26. What is Zeeman effect? Describe the experimental arrangement for studying the Zeeman effect.
27. Derive an expression for the magnetic interaction energy.
28. Explain the normal Zeeman effect on the basis of classical theory.
29. Explain the normal Zeeman effect on the basis of quantum theory.
30. Derive an expression for normal Zeeman shift.
31. Describe the anomalous Zeeman effect with help of quantum theory.

32. Derive an expression for Lande's splitting factor.
33. Explain anomalous Zeeman effect of sodium D line with help of Lande's splitting factor.
34. Calculate Zeeman shift in normal Zeeman effect. Given magnetic field=0.5T  $e/m = 1.76 \times 10^{11} \text{c/Kg}$  wavelength=5500Å.
35. Normal Zeeman shift is  $13.35 \times 10^{-12} \text{m}$  when spectral line of wavelength 6000Å is subjected to magnetic field of 0.4T. Find the value of  $e/m$ .
36. What magnetic flux density is required to observe the normal Zeeman effect if a spectrometer can resolve spectral lines separated by 1Å in the wavelength region of 8000Å.

### UNIT-II MOLECULAR SPECTRA:

37. Explain general features of molecular spectra.
38. Explain the Radiant energy sources?
39. A force constant of HCl molecule is  $5.8 \times 10^2 \text{ N/m}$  find the energy required to increase the nuclear separation.
40. Derive an expression for moment of inertia of diatomic molecule considering it as a rigid rotator.
41. Find lowest rotational energy  $J=1$  for a CO-molecule. Given mass of C- atom is 12 amu and O-atom is 16 amu.  
  
 $1 \text{amu} = 1.66 \times 10^{-27} \text{ Kg}$  and bond length=0.15nm
42. The force constant of the bond in CO molecule is 187N/m and its reduced mass is  $1.14 \times 10^{-26} \text{ Kg}$  compute the frequency of vibration of the molecule and the spacing between its vibrational energy levels.
43. Given that the rotational of CO has line spaced at 384.2/m apart. Calculate the moment of inertia and bond length of the molecule. Given [ $\mu = 1.139 \times 10^{-26} \text{ Kg}$ ,  $h = 6.625 \times 10^{-34} \text{ Js}$ ].

### RAMAN EFFECT

44. Write a short note on Raman spectra.
45. What is Raman Effect? What are the characteristics of Raman lines .
46. With exciting line 4348 Å a sample gives Stokes line 4445Å deduce the wavelength of anti -Stokes lines.
47. The exciting line in an Raman experiment is 5460Å and Stokes line is 5520Å. find the wavelength of the anti-Stokes line.
48. Describe the experimental arrangement for the study of Raman Effect.

### LASER AND HOLOGRAPHY

49. Define Einstein's A&B coefficients. Derive the relation between these coefficients.
50. Explain the construction of He-Ne laser with a neat diagram.
51. Explain the working of He-Ne laser.
52. Define the term population inversion. How is it achieved for laser action?
53. Write a note on applications of laser.
54. Explain the terms absorption, spontaneous & stimulated emission of radiation in a Laser.
55. Describe how images can be recorded & reproduced holographically.
56. What is optical pumping in Laser? Explain different types of pumping.
57. Explain the construction of Ga-As laser with neat diagram.
58. Explain the working of Ga-As laser.

### **FIBRE OPTICS**

59. Discuss in detail any four applications of optical fibers in different fields.
60. The glass material with which an optical fiber is made, has R.I. as 1.55. This material is clad with another material whose R.I. is 1.57. The light in the fiber is launched from air. Calculate
  - a. The numerical aperture of the fiber
  - b. The acceptance angle.
61. The numerical aperture of an optical fiber is 0.29 and R.I. of core 1.535. Calculate the R.I. of cladding and critical angle.
62. Explain how optical fiber is used in communication system.
63. The numerical aperture of an optical fiber is 0.29 and refractive index of core is 1.535. Calculate the refractive index of cladding and critical angle.

### **10 Mark Questions**

#### **Unit-I ATOMIC SPECTRA**

1. State the Pauli's exclusion principle and explain how it helps in fixing up the electronic configuration of the elements in the periodic table.
2. Give an account of different quantum numbers required to specify the state of an electron in the atom.
3. Mention the salient features of vector atom model and explain the different quantum numbers associated with it.
4. Explain seven quantum numbers.
5. Describe Stern-Gerlach experiment and discuss the results of it.

6. Explain Franck-Hertz experiment with neat diagram. Mention its drawbacks.
7. i) State Pauli's exclusion principle with two examples. ii) Based on Pauli's exclusion principle show that maximum number of electrons in the  $n^{\text{th}}$  orbit is  $2n^2$ .

### **MAGNETIC FIELD EFFECT ON LIGHT**

8. State Larmor's theorem. Explain normal Zeeman effect on the basis of quantum theory.
9. What is normal Zeeman effect ? Explain classical theory of normal Zeeman effect.
10. What is Zeeman effect? Explain normal Zeeman effect on the basis of quantum theory.
11. Derive an expression for Lande's splitting factor and explain anomalous Zeeman effect.
12. Explain how  $D_1$  and  $D_2$  line of sodium splits into four and six lines in a magnetic field.

### **UNIT-II MOLECULAR SPECTRA:**

13. Describe the vibrational energy of the diatomic molecule. Explain how force constant is determined using vibrational spectrum.
14. Obtain the expression for rotational energy levels of diatomic molecule and the frequency of rotational spectrum.

### **RAMAN EFFECT**

15. What is Raman effect ? Explain the classical theory of Raman effect.
16. With a neat diagram describe an experimental set up to observe Raman effect and write the characteristics of Raman Effect.

### **UNIT-III LASER AND HOLOGRAPHY**

17. What are Einstein's A and B coefficients? Obtain the relation between them.
18. Explain the construction and working of He-Ne laser and write its demerits.
19. Explain the construction and working of Ga-As laser and write its demerits.

### **FIBRE OPTICS**

20. i) What is optical fiber? Name the types of optical fiber.  
ii) Discuss in detail applications of optical fiber.

